

Magelis XBT GT, XBT GK, XBT GH

Hardware Guide

11/2012

The information provided in this documentation contains general descriptions and/or technical characteristics of the performance of the products contained herein. This documentation is not intended as a substitute for and is not to be used for determining suitability or reliability of these products for specific user applications. It is the duty of any such user or integrator to perform the appropriate and complete risk analysis, evaluation and testing of the products with respect to the relevant specific application or use thereof. Neither Schneider Electric nor any of its affiliates or subsidiaries shall be responsible or liable for misuse of the information that is contained herein. If you have any suggestions for improvements or amendments or have found errors in this publication, please notify us.

No part of this document may be reproduced in any form or by any means, electronic or mechanical, including photocopying, without express written permission of Schneider Electric.

All pertinent state, regional, and local safety regulations must be observed when installing and using this product. For reasons of safety and to help ensure compliance with documented system data, only the manufacturer should perform repairs to components.

When devices are used for applications with technical safety requirements, the relevant instructions must be followed.

Failure to use Schneider Electric software or approved software with our hardware products may result in injury, harm, or improper operating results.

Failure to observe this information can result in injury or equipment damage.

© 2012 Schneider Electric. All rights reserved.

Table of Contents

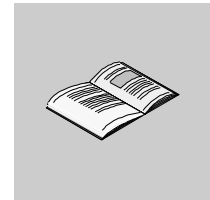

	Safety Information	7
	About the Book	9
Part I	XBT GT, XBT GK, and XBT GH Panels	11
Chapter 1	XBT GT, XBT GK, and XBT GH Panels	13
	XBT GT, GK, and GH Series of Panels	14
	Package Contents	18
	Certifications and Standards	20
Chapter 2	Device Connectivity	23
	System Design	24
	Accessories	28
Chapter 3	Specifications	35
3.1	General Specifications	36
	Electrical Specifications	37
	Environmental Specifications	38
	Structural Specifications	40
3.2	Functional Specifications	42
	Display Specifications	43
	Memory, Clock, and Touch Panel	49
	Industrial Pointer, Keypads, Switches and LEDs	52
	Insert Labels XBT GK and XBT GH	57
	Serial Interface	60
3.3	Interface Specifications	63
	Specifications of Serial Interface COM1/COM	64
	Specifications of Serial Interface COM2	68
	Other Interfaces	69
3.4	Part Numbers and Functions	72
	Parts Identification and Functions	73
	Terminal Configuration Switches	104
3.5	Dimensions	108
	XBT GT1000 Series Dimensions	109
	XBT GT1005 Series Dimensions	111
	XBT GT2000 Series Dimensions	114
	XBT GT4000 Series Dimensions	121

	XBT GT5000 Series Dimensions	125
	XBT GT6000 Series Dimensions	133
	XBT GT7000 Series Dimensions	137
	XBT GK2000 Series Dimensions	141
	XBT GK5330 Dimensions	145
	XBT GH2000 Series Dimensions	149
	Panel Cut-out Dimension	151
	Installation Fasteners	153
Chapter 4	Installation and Wiring	155
4.1	Installation	156
	Installation Procedures	156
4.2	Wiring Principles	163
	Connecting the Power Cord	164
	Connecting the Power Supply	167
	Grounding	169
	Input/Output Line Placement	171
4.3	Tool Port Connector	172
	Making Tool Port Connections	173
	USB Driver Installation	174
4.4	Ethernet Cable Connector	177
	Presentation	177
4.5	CF Card	179
	CF Card Installation and Removal	179
4.6	USB Port	182
	Important Considerations When Using the USB Port	183
	USB Data Transfer Cable (XBT ZG935) - USB Driver Installation	184
	USB Clamp	186
	USB Holder	190
4.7	AUX Connector	193
	AUX Connector	193
4.8	Cable Connector	194
	Attaching the Cable Connector to the XBT GH	194
4.9	Emergency Switch Guard	196
	Attaching the Emergency Switch Guard to the XBT GH	196
Part II	Setting and Debugging	199
Chapter 5	Settings	201
5.1	Settings	201
	Types of Settings	202
	Offline Settings	203
	System Settings	205
Chapter 6	Troubleshooting	207
	Troubleshooting Checklists	208
	Self Test List	212

Chapter 7 Maintenance	215
Regular Cleaning.....	216
Periodic Check Points	217
Replacing the Backlight.....	218
Index	221

Safety Information

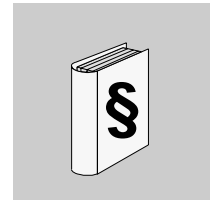

Important Information

NOTICE

Read these instructions carefully, and look at the equipment to become familiar with the device before trying to install, operate, or maintain it. The following special messages may appear throughout this documentation or on the equipment to warn of potential hazards or to call attention to information that clarifies or simplifies a procedure.



The addition of this symbol to a Danger safety label indicates that an electrical hazard exists, which will result in personal injury if the instructions are not followed.



This is the safety alert symbol. It is used to alert you to potential personal injury hazards. Obey all safety messages that follow this symbol to avoid possible injury or death.

DANGER

DANGER indicates an imminently hazardous situation which, if not avoided, **will result in** death or serious injury.

WARNING

WARNING indicates a potentially hazardous situation which, if not avoided, **can result in** death or serious injury.

 **CAUTION**

CAUTION indicates a potentially hazardous situation which, if not avoided, **can result in** minor or moderate injury.

NOTICE

NOTICE is used to address practices not related to physical injury.

PLEASE NOTE

Electrical equipment should be installed, operated, serviced, and maintained only by qualified personnel. No responsibility is assumed by Schneider Electric for any consequences arising out of the use of this material.

A qualified person is one who has skills and knowledge related to the construction and operation of electrical equipment and its installation, and has received safety training to recognize and avoid the hazards involved.

About the Book

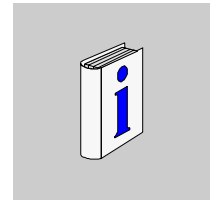

At a Glance

Document Scope

This manual describes how to use the Magelis XBT GT, XBT GK, and XBT GH devices.

Validity Note

This document is valid for Vijeo Designer v6.1 SP2.

User Comments

We welcome your comments about this document. You can reach us by e-mail at techcomm@schneider-electric.com.

XBT GT, XBT GK, and XBT GH Panels



Overview

This part presents XBT GT, XBT GK, and XBT GH Panels.

What Is in This Part?

This part contains the following chapters:

Chapter	Chapter Name	Page
1	XBT GT, XBT GK, and XBT GH Panels	13
2	Device Connectivity	23
3	Specifications	35
4	Installation and Wiring	155

XBT GT, XBT GK, and XBT GH Panels



1

Overview

This chapter presents series of XBT GT, XBT GK, and XBT GH Panels and connectable devices.

What Is in This Chapter?

This chapter contains the following topics:

Topic	Page
XBT GT, GK, and GH Series of Panels	14
Package Contents	18
Certifications and Standards	20

XBT GT, GK, and GH Series of Panels

Introduction

The following presents the XBT GT touchscreen, XBT GK keypad, and XBT GH hand held series of human-machine interface (HMI) products. These products have an operating voltage of 24 Vdc. The products offered in this series have various features and benefits listed below:

- Screen size
- Screen resolution
- Screen technology and color
- Communication ports

XBT GT Part Numbers

The following table presents the different XBT GT products:

Part number	Screen size	Pixel resolution	Mono/Color	Screen technology	Video port	Ethernet port
XBT GT1100	9,6 cm (3.8 in.)	QVGA	Amber	STN	No	No
XBT GT1105	9,6 cm (3.8 in.)	QVGA	Amber	STN	No	No
XBT GT1130	9,6 cm (3.8 in.)	QVGA	Amber	STN	No	Yes
XBT GT1135	9,6 cm (3.8 in.)	QVGA	Amber	STN	No	Yes
XBT GT1335	9,6 cm (3.8 in.)	QVGA	Color	TFT	No	Yes
XBT GT2110	14,4 cm (5.7 in.)	QVGA	Blue Mode	STN	No	No
XBT GT2120	14,4 cm (5.7 in.)	QVGA	Monochrome	STN	No	No
XBT GT2130	14,4 cm (5.7 in.)	QVGA	Monochrome	STN	No	Yes
XBT GT2220	14,4 cm (5.7 in.)	QVGA	Color	STN	No	No
XBT GT2330	14,4 cm (5.7 in.)	QVGA	Color	TFT	No	Yes
XBT GT2430	14,4 cm (5.7 in.)	VGA	Color	TFT	No	Yes
XBT GT2930	14,4 cm (5.7 in.)	QVGA	Color	TFT	No	Yes
XBT GT4230	19,1 cm (7.5 in.)	VGA	Color	STN	No	Yes
XBT GT4330	19,1 cm (7.5 in.)	VGA	Color	TFT	No	Yes
XBT GT4340	19,1 cm (7.5 in.)	VGA	Color	TFT	Yes	Yes
XBT GT5230	26,4 cm (10.4 in.)	VGA	Color	STN	No	Yes
XBT GT5330	26,4 cm (10.4 in.)	VGA	Color	TFT	No	Yes
XBT GT5340	26,4 cm (10.4 in.)	VGA	Color	TFT	Yes	Yes
XBT GT5430	26,4 cm (10.4 in.)	SVGA	Color	TFT	No	Yes
XBT GT6330	30,7 cm (12.1 in.)	SVGA	Color	TFT	No	Yes

Part number	Screen size	Pixel resolution	Mono/Color	Screen technology	Video port	Ethernet port
XBT GT6340	30,7 cm (12.1 in.)	SVGA	Color	TFT	Yes	Yes
XBT GT7340	38,1 cm (15.0 in.)	XGA	Color	TFT	Yes	Yes

- STN: Super-Twisted Nematic, also known as passive matrix.
- TFT: Thin Film Transistors, also known as active matrix.

XBT GK Part Numbers

The following table presents the different XBT GK products:

Part number	Screen size	Pixel resolution	Mono/Color	Screen technology	Video port	Ethernet port
XBT GK2120	14,4 cm (5.7 in.)	QVGA	Monochrome	STN	No	No
XBT GK2330	14,4 cm (5.7 in.)	QVGA	Color	TFT	No	Yes
XBT GK5330	26,4 cm (10.4 in.)	VGA	Color	TFT	No	Yes

- STN: Super-Twisted Nematic also known as passive matrix.
- TFT: Thin Film Transistors also known as active matrix.

XBT GH Part Numbers

The following table presents the different XBT GH products:

Part number	Screen size	Pixel resolution	Mono/Color	Screen technology	Video port	Ethernet port
XBT GH2460	14,4 cm (5.7 in.)	VGA	Color	TFT	No	Yes

- TFT: Thin Film Transistors also known as active matrix.

Critical systems, alarms and handling Requirements

Critical alarm indicators and system functions require independent and redundant protection hardware and/or mechanical interlocks.

When you cycle power, wait at least 10 seconds before restoring the power to the HMI unit after it has been turned off. Switching the power OFF and ON quickly can damage the unit.

In the event the screen can not be properly read, for example, if the backlight is not functioning, it may be difficult or impossible to identify a function. Functions that may present a hazard if not immediately executed, such as a fuel shut-off, must be provided independently of the unit. The machine's control system design must take into account the possibility of the backlight no longer functioning and the operator being unable to control the machine or making errors in the control of the machine.

WARNING

LOSS OF CONTROL

- The designer of any control scheme must consider the potential failure modes of control paths and, for certain critical control functions, provide a means to achieve a safe state during and after a path failure. Examples of critical control functions are emergency stop and overtravel stop.
- Separate or redundant control paths must be provided for critical control functions.
- System control paths may include communication links. Consideration must be given to the implications of unanticipated transmission delays or failures of the link.
- Each implementation of the Magelis XBT GT/XBT GK/XBT GH must be individually and thoroughly tested for proper operation before being placed into service.
- The machine control system design should take into account the possibility of the backlight no longer functioning and the operator being unable to control the machine, or making errors in the control of the machine.

Failure to follow these instructions can result in death, serious injury, or equipment damage.

WARNING

UNINTENDED EQUIPMENT OPERATION

- Do not use the unit as the only means of control for critical system functions such as motor start/stop or power disconnect
- Do not use the unit as the only notification device for critical alarms, such as device overheating or overcurrent

Failure to follow these instructions can result in death, serious injury, or equipment damage.

Handling the LCD panel

The following characteristics are specific to the LCD unit and are considered normal behavior:

- LCD screen may show unevenness in the brightness of certain images or may appear different when seen from outside the specified viewing angle. Extended shadows, or crosstalk may also appear on the sides of screen images.
- LCD screen pixels may contain black and white colored spots and color display may seem to have changed.
- When the same image is displayed on the unit's screen for a long period, an afterimage may appear when the image is changed. If this happens, turn OFF the unit, wait 10 sec and then restart the unit.

NOTE: Change the screen image periodically and try not to display the same image for a long period of time.

CAUTION

SERIOUS EYE AND SKIN INJURY

The LCD panel's liquid contains an irritant. Avoid direct skin contact with the liquid.

- Wear gloves when you handle a broken or leaking unit.
- Do not use sharp objects or tools in the vicinity of the LCD touch panel or to operate its buttons.
- Handle the LCD panel carefully to prevent puncture, bursting, or cracking of the panel material.

If the panel is damaged and any liquid comes in contact with your skin, immediately rinse the area with running water for at least 15 min. If the liquid gets in your eyes, immediately rinse your eyes with running water for at least 15 min and consult a doctor.

Failure to follow these instructions can result in injury or equipment damage.

Package Contents

Make sure all applicable items listed here are present in your unit's package:

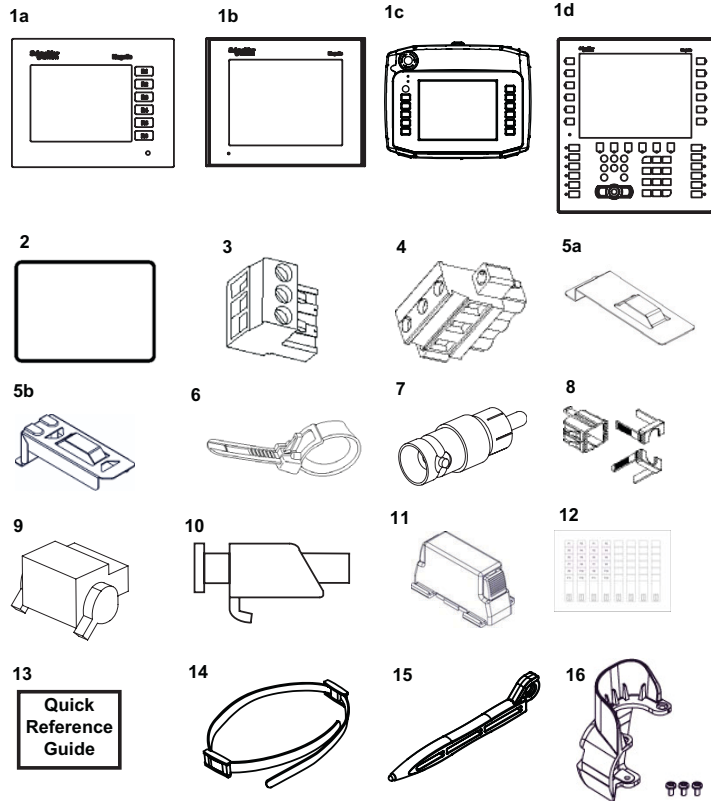

- 1a or 1b or 1c or 1d** Human Machine Interface
- 2** Installation Gasket (not available for the XBT GH series)
- 3** Power Plug (for XBT GT1000/1005/2000/4000 series, XBT GK2000 series)
- 4** Power Plug (for XBT GT5000/6000/7000 series, XBT GK5000 series)
- 5a** USB Holder (for XBT GT2000 series)
- 5b** USB Holder (for XBT GK series)
- 6** USB Cable Clamp (for XBT GT2000 series, XBT GK series)
- 7** RCA-BNC Converter (for XBT GT4340/5340/6340/7340)

-
- 8 USB Holder, 1 set (for XBT GT1005/4000/5000/6000/7000 series)
 - 9 AUX Connector (for XBT GT4000/5000/6000/7000 series, XBT GK5000 series)
 - 10 Screw installation fasteners (XBT GT1005/2000/4000/5000/6000 series: x4, XBT GT7000 series: x8, XBT GK series: none)
 - 11 Spring Clip (for XBT GK2000 series: x10, XBT GK5000 series: x12)
 - 12 "Insert Labels" set (for XBT GK series and XBT GH series: contains 2 sets of premarked labels and 4 blank labels)
 - 13 Quick Reference Installation guide
 - 14 Hand Strap for XBT GH
 - 15 Touch Pen stylus for XBT GH
 - 16 Emergency Switch Guard for XBT GH

Revision

You can identify the product version (PV), revision level (RL), and the software version (SV) from the product label sticker pasted on the unit.

The following diagram show a typical representation of label sticker:

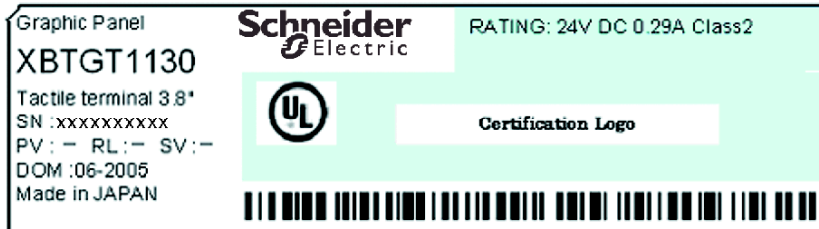

Certifications and Standards

Agency Certifications

Schneider Electric submitted this product for independent testing and qualification by third-party listing agencies. These agencies have certified this product as meeting the following standards.

Agency Certifications for XBTGT and XBTGK Series

North America: XBT GT and XBT GK series certified by Underwriters Laboratories Inc. and/or Canadian Standard Association against:

- UL508, Industrial Control Equipment
- CSA-C22.2, No. 142-M1987 - Standard for Process Control Equipment
- ANSI/ISA - 12.12.01⁽¹⁾ Electrical Equipment for Use in Class I Division 2 Hazardous Locations
- CAN/CSA-C22.2, No.14, No.213⁽¹⁾ - For Hazardous Locations

(1) Except for XBT GT2930.

Some XBT GT terminals are type approved by Marine Agencies⁽²⁾:

- RMRS Russia
- RINA Italy
- LR United Kingdom
- GL Germany
- DNV Norway
- BV France
- ABS United States of America

For detailed information, contact your local distributor.

(2) Except for XBT GT2430/2930/5430.

NOTE: XBT GT Series conform to ATEX directive No. 94/9/EC (refer to the certificate and marking provided with the product).

Agency Certifications for XBT GH

North America:

- Underwriters Laboratories Inc., UL508, Industrial Control Equipment

Compliance Standards

Schneider Electric tested this product for compliance with the following compulsory standards and directives.

Compliance Standards for XBT GT and XBT GK Series

Europe:

- Directive 2006/95/EC (Low voltage)
- Directive 2004/108/EC (EMC).

The units are CE marked. For detailed information, contact your local distributor.

- Programmable Controllers: EN/IEC 61131-2
- EMI: EN 55011 (Group 1, Class A)
- EMC: EN 61000-6-2
- Australia: C-Tick N998, standard AS/NZS CISPR11

Compliance Standards for XBT GH

Europe:

- Directive 2006/95/EC (Low voltage)
- Directive 2004/108/EC (EMC).

The units are CE marked. For detailed information, contact your local distributor.

- Programmable Controllers: EN/IEC 61131-2
- EMI: EN 55011 (Group 1, Class A) / IEC 61000-3-2, IEC 61000-3-3
- EMC: EN 61000-6-2
- Australia: C-Tick N998, standard AS/NZS CISPR11

XBT GH Safety Circuit:

- Go to the Schneider Electric website to learn about the safety level that the safety circuit can be evaluated to.

Qualification Standards

Schneider Electric voluntarily tested this product to additional standards. The additional tests performed, and the standards under which the tests were conducted, are specifically identified in Environmental Characteristics (*see page 38*).

Hazardous Substances

The XBT GK, XBT GT, and XBT GH Series are designed for compliance with:

- WEEE, Directive 2002/96/EC

This product is compliant with:

- RoHS, Directive 2002/95/EC
- RoHS China, Standard SJ/T 11363-2006

ANSI/ISA 12.12.01 Conditions of Acceptability and Handling Considerations for XBT GT and XBT GK Series

The XBT GT and XBT GK series have been designed to operate in hazardous locations in accordance with Class 1, Division 2 standards*. All relevant local, state, and regional codes must be followed.

* Except for XBT GT2930.

DANGER

EXPLOSIVE POTENTIAL

- Only use this equipment in non-hazardous locations or in locations that comply with Class I, Division 2, Groups A, B, C and D.
- Do not perform substitution of components that may impair compliance to Class I, Division 2.
- Confirm that the location is not subject to any risk of explosion before connecting or disconnecting equipment, replacing or wiring modules.
- Confirm that the externally connected unit and each interface (COM1, COM2, EXT1, EXT2, CF Card, AUX) and the CF Card Cover and the AUX Connector have been securely locked.
- Confirm that the power supply has been turned OFF before disconnecting, replacing or wiring modules.
- Before turning ON, wipe front panel with a damp cloth.

Failure to follow these instructions will result in death or serious injury.

Device Connectivity



Introduction

This chapter presents the equipment connectable to each XBT GT, XBT GK, and XBT GH unit.

What Is in This Chapter?

This chapter contains the following topics:

Topic	Page
System Design	24
Accessories	28

System Design

Introduction

The following diagrams represent the main selection of equipment connectable to the units.

XBT GT1000 Series Edit Mode Peripherals

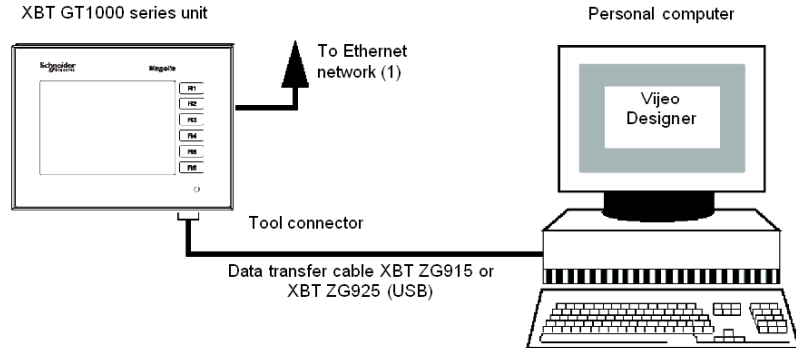

(1) Not available on XBT GT1100

XBT GT1005/2000/4000/5000/6000/7000 Series, XBT GK2000/5000, and XBT GH Series Edit Mode Peripherals

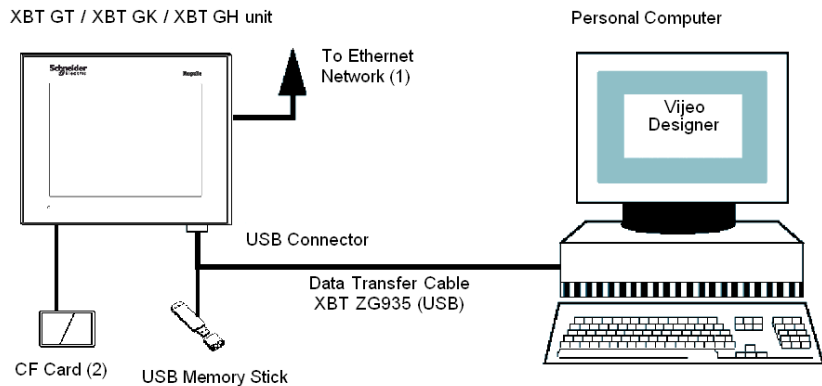

(1) Not available on XBT GT1105/2110/2120/2220 and XBT GK2120

(2) Not available on XBT GT1105/1135/1335/2110

XBT GT1000 Series Run Mode Peripherals

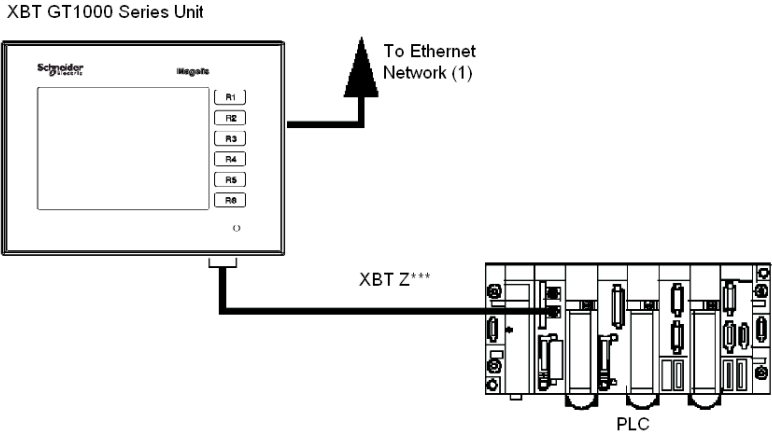

(1) Not available on XBT GT1100

XBT GT1005/2000/4000/5000/6000/7000 and XBT GK2000/5000 Series Run Mode Peripherals

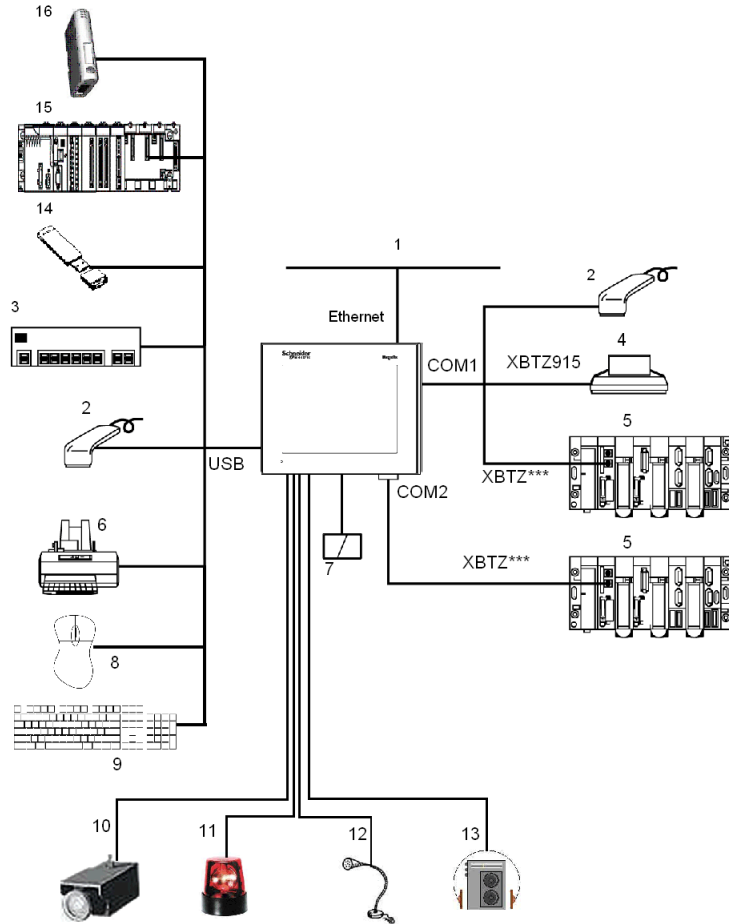

- 1 Ethernet network connection (not available on XBT GH, XBT GT1105/2110/2120/2220 and XBT GK2120)
- 2 Serial bar code reader (validated with Gryphon range of Datalogic)
- 3 USB hub (commercial type)
- 4 Serial printer
- 5 PLC
- 6 Parallel printer (printer function validated with EPSON and HP models; details available on Vijeo Designer documentation)
- 7 Compact Flash (CF) Card (not available on XBT GT1105/1135/1335/2110)
- 8 USB Mouse
- 9 USB Keyboard

- 10 Camera (available on XBT GTxx40 products only and Vijeo Designer Version higher than V4.3)
- 11 Flashing light (not available on XBT GT1005/2000 series and XBT GK2000 series)
- 12 Microphone (available on XBT GTxx40 products only and Vijeo Designer Version higher than V4.3)
- 13 Speaker (not available on XBT GT1005/2000 series and XBT GK2000 series)
- 14 USB Memory Stick
- 15 PLC with USB Terminal port (Modicon M340)
- 16 Communication Gateway (ModbusPlus or Fipio)

XBT GH Series Run Mode Peripherals

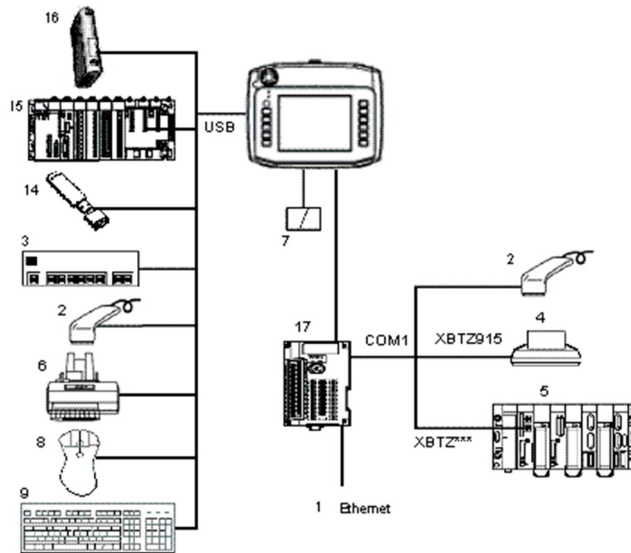

- 1 Ethernet network connection (not available on XBT GH XBT GT1105/2110/2120/2220 and XBT GK2120)
- 2 Serial bar code reader (validated with Gryphon range of Datalogic)
- 3 USB hub (commercial type)
- 4 Serial printer
- 5 PLC
- 6 Parallel printer (printer function validated with EPSON and HP models; details available on Vijeo Designer documentation)
- 7 CF Card (not available on XBT GT1105/1135/1335/2110)
- 8 USB Mouse
- 9 USB Keyboard
- 14 USB Memory Stick)
- 15 PLC with USB Terminal port (Modicon M340)
- 16 Communication Gateway (ModbusPlus or Fipio)
- 17 Conversion Adaptor (XBT GH only, required for communications with PLC)

Accessories

Serial Interface Items

Product Number	Product name	Description	XBT GT/GK/GH series
XBT Z915	Cable	Connects COM on XBT GH, COM1 port on GT/GK to a serial printer.	All XBT GK models, XBT GT2000 and higher, XBT GH
XBT Z9780	XBT Z cable	Connects COM1 on XBT GT1000/1005 series, COM2 on XBT GK and XBT GT2000 and higher, and LAN on XBT GH series to Premium, Micro, Twido PLC	All
XBT Z9980	XBT Z cable	Connects COM1 on XBT GT1000/1005 series, COM2 on XBT GK and XBT GT2000 and higher, and LAN on XBT GH series to Modicon M340. (length 2.5 m / 98.42 in.).	All
VW3A8306	XBT Z cable	Connects COM1 on XBT GT1000/1005 series, COM2 on XBT GK and XBT GT2000 and higher, and LAN on XBT GH series to derivation box TSXSCA62	All
VW3A8306R10	XBT Z cable	Connects COM1 on XBT GT1000/1005 series, COM2 on XBT GK and XBT GT2000 and higher, and LAN on XBT GH series to ATV Drives or to Hub LU9GC3 or to Fieldbus Tap TWDXCAT3RJ, TWDXCAISO	All
STBXCA4002	XBT Z cable	Connects COM1, COM on XBT GH, port to Advantys STB	All XBT GK models, XBT GT2000 and higher, XBT GH
TSXPCX1031	XBT Z cable	Connects COM1, COM on XBT GH, port to Premium, Micro, Twido	All XBT GK models, XBT GT2000 and higher, XBT GH
XBT ZG909	XBT Z adapter	Cable adapter COM1, COM on XBT GH, D-Sub9 RS-485	All XBT GK models, XBT GT2000 and higher, XBT GH
XBT ZG919	XBT Z adapter	Cable adapter COM1, COM on XBT GH, D-Sub9 RS-232	All XBT GK models, XBT GT2000 and higher, XBT GH
XBT ZG939	XBT Z adapter	Cable adapter COM1, LAN on XBT GH RJ45	XBT GT1000/1005, XBT GH
XBT Z968 XBT Z9680 XBT Z9681	XBT Z cable	Connects COM1, COM on XBT GH, port with XBTZ adapter to Premium, Micro, Twido PLC	All
XBT Z9710	XBT Z cable	Connects COM1, COM on XBT GH, port with XBTZ adapter to Quantum PLC	All

Product Number	Product name	Description	XBT GT/GK/GH series
XBT Z9711	XBT Z cable	Connects COM1, COM on XBT GH, port with XBTZ adapter to Momentum PLC	All
XBT Z908	XBT Z cable	Connects COM1, COM on XBT GH, port with XBTZ adapter to derivation box TSXSCA62	All XBT GK models, XBT GT2000 and higher, XBT GH
XBT Z938	XBT Z cable	Connects COM1, COM on XBT GH, port with XBTZ adapter to ATV drives or to Hub LU9GC3 or to Fieldbus Tap TWDXCAT3RJ, TWDXCAISO	All XBT GK models, XBT GT2000 and higher, XBT GH
XBT Z918	XBT Z cable	Connects COM1, COM on XBT GH, port with XBTZ adapter to Premium SCY	All
XBT Z988	XBT Z cable	Connects COM1, COM on XBT GH, port with XBTZ adapter to Advantys STB	All
XBT ZGI232	XBT Z isolation	Connects COM1, COM on XBT GH, port to an equipment and provide isolation	All XBT GK models, XBT GT2000 and higher, XBT GH
XBT ZGI485	XBT Z isolation	Connects COM2 port to an equipment and provide isolation	All XBT GK models, XBT GT2000 and higher
XBT ZGCOM1	Port adapter	Connects COM1, COM on XBT GH, port to optional RS-422 equipment	All XBT GK models, XBT GT2000 and higher, XBT GH
XBT ZGCOM2	Port adapter	Connects COM2, LAN on XBT GH, port to optional RS-485 equipment	All XBT GK models, XBT GT2000 and higher, XBT GH
XBT ZG9731	XBT Z cable	Connects COM1, COM on XBT GH, to Mitsubishi PLC A series link unit or to Rockwell DF1 Logix PLC	All XBT GK models, XBT GT2000 and higher, XBT GH
XBT ZG9772	XBT Z cable	Connects COM1, COM on XBT GH, to Mitsubishi PLC Q series link unit	All XBT GK models, XBT GT2000 and higher, XBT GH
XBT ZG9773	XBT Z cable	Connects COM1, COM on XBT GH, to Mitsubishi PLC A series CPU	All XBT GK models, XBT GT2000 and higher, XBT GH
XBT ZG9774	XBT Z cable	Connects COM1, COM on XBT GH, to Mitsubishi PLC Q series CPU	All XBT GK models, XBT GT2000 and higher, XBT GH
XBT ZG9775	XBT Z cable	Connects COM1, COM on XBT GH, to Mitsubishi PLC FX series CPU	All XBT GK models, XBT GT2000 and higher, XBT GH
XBT ZG9740	XBT Z cable	Connects COM1, COM on XBT GH, to Omron PLC Sysmac Link series	All XBT GK models, XBT GT2000 and higher, XBT GH

Product Number	Product name	Description	XBT GT/GK/GH series
XBT ZG9722	XBT Z cable	Connects COM1, COM on XBT GH, to RS-422 devices	All XBT GK models, XBT GT2000 and higher, XBT GH
XBT ZG9778	XBT Z cable	Connects COM1, COM on XBT GH, with port adapter to Mitsubishi PLC with Melsec 2 port adapter	All XBT GK models, XBT GT2000 and higher, XBT GH
XBT ZG979	Adapter		All XBT GK models, XBT GT2000 and higher, XBT GH
XBT ZG949	Adapter	Terminal RS-422 block to connect COM1, COM on XBT GH, with port adapter to RS-422 devices	All XBT GK models, XBT GT2000 and higher, XBT GH
XBT ZG9721	XBT Z cable	Connects COM1 or COM2, COM on XBT GH, to Siemens PPI PLC	All
XBT ZG9292	XBT Z cable	Connects COM1, COM on XBT GH, to Siemens MPI PLC	All XBT GK models, XBT GT2000 and higher, XBT GH
XBT Z9730 XBT Z9731	XBT Z cable	Connects COM1, LAN on XBT GH, with XBT Z adapter to Rockwell DF1 PLC	XBT GT1000/1005, XBT GH
XBT Z9732	XBT Z cable	Connects COM1, with XBT Z adapter to Rockwell DH485 PLC	All
XBT Z9740	XBT Z cable	Connects COM1, LAN on XBT GH, with XBT Z adapter to Omron PLC Sysmac Link series	XBT GT1000/1005, XBT GH
XBT Z9720	XBT Z cable	Connects COM1, with XBT Z adapter to Siemens 3964/RK512	All

XBT GT Tool Port Items

Product Number	Product name	Description	XBT GT series
XBT ZG915 (for PC Serial Port) XBT ZG925 (for PC USB Port)	Cable	Connects the XBT GT to a personal computer. Transfers screen data and user program(s).	XBT GT1000

USB Interface Items

Product Number	Product name	Description	XBT GT/GK/GH series
XBT ZG935	Cable	Connects the panel to a personal computer. Transfers screen data and user program	XBT GT1005/2000, XBT GK2000, XBT GH
XBT ZGUSB	Cable	Extends a USB host interface on a cabinet with waterproofness	All XBT GK, XBT GH models, XBT GT1005 and higher
XBT ZGUMP	Gateway	Connects panels to Modbus Plus Fieldbus	All XBT GK, XBT GH models, XBT GT2000 and higher
TSX C USB FIP	Gateway	Connects panels to Fipio Fieldbus	All XBT GK, XBT GH models, XBT GT2000 and higher
BMX XCA USB 018	Cable	Connects the panel to a USB terminal port of a PLC (Modicon M340)	All XBT GK, XBT GH models, XBT GT1005 and higher

Software

Product name	Description
Vijeo Designer: <ul style="list-style-type: none"> ● version 4.3 or higher for XBT GT ● Version 4.6 or higher for XBT GK ● Version 5.1 or higher for XBT GH 	Software used to create HMI unit project data. It is installed in a personal computer.

Screen Protection Sheets

Product Number	Description	XBT GT/GK/GH series
XBT ZG60	<ul style="list-style-type: none"> ● Dirt-resistant sheet ● The touch panel can be operated with this cover sheet attached ● 5 sheets/pack 	XBT GT1005
XBT ZG61		XBT GT1000
XBT ZG62		XBT GT2000
XBT ZG64		XBT GT4000
XBT ZG65		XBT GT53xx
XBT ZG66		XBT GT6000, XBT GT52xx
MPC YK5 0SPS KIT		XBT GT7000
XBT ZG68		XBT GK2000
XBT ZG69		XBT GK5000
XBLYGH2		XBT GH

Spring Clip Fasteners

Product Number	Description	XBT GT/GK series
XBT Z3002	Fasteners attach the panel to a mounting surface for IP65 (1) protection on XBT GT and IP65 (1)/Nema4 on XBT GK: 12 clips/pack	All

NOTE: The protection level of the product may vary from that which is shown on the ATEX label, as the value on the ATEX label takes into account product aging.

An old gasket can lose its dust and drip resistance. Changing the gasket once a year or when scratches or dirt becomes visible is recommended.

Communication Modules

Product Number	Product Name	Description	XBT GT/GK series
XBT ZGPDP	Profibus DP module	These modules are used to connect XBT GT/GK to Fieldbus. They are piggy back modules for the XBT GT/GK panels.	All XBT GT/GK models except XBT GT1000 and 1005 series.
XBT ZGDVN	Device Net module		

Compact Flash Memory Card Interface

The Compact Flash memory card is used for XBT GT 2000 series and higher except XBT GT2110 units and all XBT GK and XBT GH models.

This slot accepts any of the following Compact Flash (CF) memory cards:

- XBT ZGM128 (128 Mb)
- XBT ZGM256 (256 Mb)
- MPC YN0 0CFE 00N (512 Mb)
- MPC YN0 0CF10 0N (1 Gb)

Maintenance Options

Product Number	Product name	Description	XBT GT/GK series
XBT ZGFIX	Screw installation fastener	Fasteners to attach the panel to a mounting surface. (4 fasteners/pack)	All
XBT ZG51	Installation gasket	Provides a moisture resistant seal. Same as the seal included in the original package.	XBT GT1000/1005
XBT ZG52			XBT GT2000
XBT ZG54			XBT GT4000
XBT ZG55			XBT GT53xx
XBT ZG56			XBT GT6000 and XBT GT52xx
XBT ZG57			XBT GT7000
XBT ZG58			XBT GK2000
XBT ZG59			XBT GK5000
XBT ZGAUX	Auxiliary connector	Interface to control external reset, alarm output, buzzer output, and sound output.	XBT GK5000 and XBT GT4000 and higher
XBT ZGCLP1	USB clamp	Fastens onto a USB interface and prevents the USB cable from being disconnected.	XBT GT 2000
XBT ZGCLP2	USB holder		XBT GT except XBT GT1000/2000
XBT ZGCLP3	USB clamp		XBT GK
XBT ZGPWS1	Power connector	Supplies power to the unit.	XBT GT1000/1005 and XBT GT/GK2000
XBT ZGPWS2			XBT GK5000 and XBT GT 4000 and higher
XBT LYGK2	Sheets of changeable labels	Removable labels for identifying function keys.	XBT GK2000
XBT LYGK5			XBT GK5000

XBT GH Accessories

Product Number	Product name	Description	XBT GH series
XBT ZGHSTP	Hand Strap	Secures the XBT GH to the user's hand while in use to prevent accidental dropping	All XBT GH models
XBT ZGPEN	Touch Pen	Draws information on the touch screen	All XBT GH models
XBT ZGESGD	Emergency Switch Guard	Covers Emergency Switch, on units with Emergency Switch	All XBT GH models

Specifications

3

Overview

This chapter presents the XBT GT, XBT GK, and XBT GH specifications:

What Is in This Chapter?

This chapter contains the following sections:

Section	Topic	Page
3.1	General Specifications	36
3.2	Functional Specifications	42
3.3	Interface Specifications	63
3.4	Part Numbers and Functions	72
3.5	Dimensions	108

3.1 General Specifications

Overview

This section presents XBT GT, XBT GK, and XBT GH general specifications:

What Is in This Section?

This section contains the following topics:

Topic	Page
Electrical Specifications	37
Environmental Specifications	38
Structural Specifications	40

Electrical Specifications

Specification	XBT GT1000 series	XBT GT1005 series	XBT GT2000, XBT GK2000, XBT GH2000 series	XBT GT4000 series	XBT GT5000, XBT GT6000, XBT GK5000 series	XBT GT7000 series
Rated Input Voltage	24 Vdc					
Input Voltage Limits	19.2...28.8 Vdc					
Acceptable Voltage Drop	≤1 ms		≤5 ms ¹	≤10 ms		
Power Consumption	≤7 W	≤13 W	≤26 W ²	≤28 W	≤50 W ³	≤50 W
In-Rush Current	≤50 A	≤85 A	≤30 A ⁴			
Voltage endurance between power terminal and frame ground (FG)	500 VAC 20 mA for 1 min					
Insulation Resistance between power terminal and FG	20 MΩ or higher at 500 Vdc		10 MΩ or higher at 500 Vdc			
¹ except for XBT GT2110 and XBT GH series: ≤10 ms ² except for XBT GT2110: ≤18 W and XBT GH series: ≤16.7 W ³ except for XBT GT5230: ≤26 W) ⁴ except for XBT GH series: ≤60 A						

NOTE: For in-rush current, the FWHM (full-width, half maximum) value is approximately 50 μs. (When exceeding 25 A)

Environmental Specifications

Specification	Value
Ambient operating temperature (cabinet interior & panel face)	0...40 °C (32...104 °F) (1) 0...50 °C (32...122 °F) for XBT GT
Storage temperature	-20...60 °C (-4...140 °F)
Damp Heat Withstand	25...60°C / 93% Rh
Air purity (dust)	≤0.1 mg/m ³ (non-conductive levels)
Pollution degree	2
Corrosive gases	Free of corrosive gases
Atmospheric endurance (XBT GT operation altitude)	800...1,114 hPa (2,000 m (6561 ft) or lower)
Vibration immunity	IEC 60068- 2 - 6 <ul style="list-style-type: none"> ● Industry: (XBT GT, XBT GH and XBT GK series) 5...9 Hz 3.5 mm, 9...150 Hz 1 g. ● Marine: (XBT GT series) 3...13 Hz 1mm, 13...100 Hz 0,7g.
Electromagnetic Interference (EMI) immunity (via EMI simulator)	1000 Vp-p (except XBT GT7000 series), 1500 Vp-p for XBT GT7000 series. Pulse duration: 1 μs Rise time:1 ns
Concussion Resistance (XBT GH only)	IEC/EN 61131-2 compliant (147 m/s ² X, Y, Z directions for 3 times)
Drop Resistance (XBT GH only)	IEC 61131-2 compliant 1.0 meter drop - 2 times
Protection (front panel)	IP 65 - (IEC 60529) for XBT GT Series, XBT GH Series, and XBT GK Series Enclosure type, 4X indoor use with screw installation fasteners only for XBT GT series and with spring clips fasteners only for XBT GK series.
Protection (rear panel)	IP 20 - (IEC 60529) for XBT GT Series and XBT GK Series IP 65 - (IEC 60529) for XBT GH Series
Radiated radio frequency electromagnetic field	IEC 61000 - 4 - 3 10 V / m
Electrical fast transient burst	IEC 61000- 4 - 4 2 kV (power supply and I/O) 1 kV other ports

Specification	Value
High Energy Surges	IEC 61000 - 4 - 5 1 kV (Differential Mode on power supply) 2 kV (Common Mode on power supply)
Shocks	IEC 60068 - 2 - 27 1/2 sinusoidal pulse for 11 ms, 15 g on 3 axes
Electrostatic Discharge Immunity	IEC 61000-4-2 6 kV contact, 8 kV air for XBT GT series 4 kV contact, 8 kV air for XBT GK series

NOTE: (1) For XBT GT and XBT GK, the LCD display's contrast STN color and monochrome models (*see page 43*) may decrease when displays are used for hours at over 40° C (104° F) ambient operating temperature. After the temperature returns to normal, the display's contrast will be restored to normal. The unit's operation will not be affected even though the display's contrast is reduced.

Do not store the HMI unit in an area where the temperature is lower than that recommended in the unit's specifications. Doing so may cause the LCD display's liquid to freeze, which can damage the LCD. Also, if the storage area's temperature becomes higher than the specified level, the LCD's liquid may cause irreversible damage to the LCD:

CAUTION

STORAGE AND OPERATION OUTSIDE OF SPECIFICATIONS

- Store the unit in areas where temperatures are within the unit's specifications.
- Do not restrict nor block the unit's rear-face ventilation slots.

Failure to follow these instructions can result in injury or equipment damage.

Air quality requirements

Do not operate or store the unit where chemicals evaporate, or where chemicals are present in the air:

- Corrosive chemicals: Acids, alkalines, liquids containing salt.
- Flammable chemicals: Organic solvents.

CAUTION

INOPERATIVE EQUIPMENT

Do not allow water, liquids, metal, and wiring fragments to enter the HMI case.

Failure to follow these instructions can result in injury or equipment damage.

Structural Specifications

Specification	XBT GT1000/1005 series	XBT GT2000 series	XBT GT4000 series
Grounding	Observe local codes and standards. The ground connection must have a resistance $\leq 100 \Omega$ and the ground wire must have a cross section of at least 2 mm^2 (14 AWG).		
Rating (For front panel or installed unit)	IP65 (IEC 60529) (1) NEMA # 250 Type 4X/13 (2), indoor use only		
External dimensions W x H x D	130 x 140 x 41 mm (5.12 x 4.09 x 1.61 in.)	167.4 x 135 x 59.5 mm (6.60 x 5.32 x 2.34 in.)	215 x 170 x 60 (8.46 x 6.69 x 2.36 in.)
Weight	$\leq 0.4 \text{ kg}$ (0.9 lbs)	$\leq 1.0 \text{ kg}$ (2.20 lbs)	$\leq 1.8 \text{ kg}$ (4.0 lbs)
Cooling Method	Natural air circulation		

Specification	XBT GT5000 series except for XBT GT5230	XBT GT6000 series, XBT GT5230	XBT GT7000 series
Grounding	Observe local codes and standards. The ground connection must have a resistance $\leq 100 \Omega$ and the ground wire must have a cross section of at least 2 mm^2 (14 AWG).		
Rating (For front panel or installed unit)	IP65 (IEC 60529)		
External dimensions W x H x D	270.5 x 212.5 x 57 mm (10.65 x 8.37 x 2.24 in.)	313 x 239 x 56 mm (12.32 x 9.41 x 2.20 in.)	395 x 294 x 60 mm (15.55 x 11.57 x 2.36 in.)
Weight	$\leq 2.5 \text{ kg}$ (5.5 lbs)	$\leq 3.0 \text{ kg}$ (6.6 lbs)	$\leq 5.6 \text{ kg}$ (12.3 lbs)
Cooling Method	Natural air circulation		

Specification	XBT GK2000 series	XBT GK5330
Grounding	Observe local codes and standards. The ground connection must have a resistance $\leq 100 \Omega$ and the ground wire must have a cross section of at least 2 mm^2 (14AWG).	
Rating (For front panel or installed unit)	IP65 (IEC 60529) (1) NEMA # 250 Type 4X/13, indoor use only	
External dimensions W x H x D	220.3 x 265 x 60.3 mm (8.66 x 10.34 x 2.374 in.)	296 x 332 x 72.7 mm (11.65 x 13.07 x 2.862 in.)
Weight	$\leq 1.8 \text{ kg}$ (4.0 lbs)	$\leq 3.7 \text{ kg}$ (6.0 lbs)
Cooling Method	Natural air circulation	

Specification	XBT GH2000 series
Grounding	Observe local codes and standards. The ground connection must have a resistance $\leq 100 \Omega$ and the ground wire must have a cross section of at least 2 mm^2 (14AWG).
Rating (For front panel or installed unit)	IP65 (IEC 60529) (1)
External dimensions W x H x D	224 x 174 x 87.1 mm (8.82 x 7.01 x 3.40 in.)
Weight	$\leq 1 \text{ kg}$ (2.2 lbs)
Cooling Method	Natural air circulation

NOTE: (1) The front face of the unit, installed in a solid panel, has been tested using conditions equivalent to the standards shown in the specification. Therefore, prior to installing the unit, be sure to confirm the type of conditions that will be present in the operating environment. If the installation gasket is removed from the panel, the original protection level cannot be guaranteed. To maintain the original protection level, replace the installation gasket every year.

(2) XBT GT2930 does not support NEMA # 250 Type 4X/13.

3.2 Functional Specifications

Overview

This section presents the XBT GT, XBG GK, and XBT GH functional specifications of the display, memory and interfaces.

What Is in This Section?

This section contains the following topics:

Topic	Page
Display Specifications	43
Memory, Clock, and Touch Panel	49
Industrial Pointer, Keypads, Switches and LEDs	52
Insert Labels XBT GK and XBT GH	57
Serial Interface	60

Display Specifications

STN Displays

Specification	XBT GT1100 XBT GT1130 XBT GT1105 XBT GT1135	XBT GT2110	XBT GT2120 XBT GT2130 XBT GK2120	XBT GT2220	XBT GT4230	XBT GT5230
Type	Monochrome LCD	Monochrome (Blue mode) LCD	Monochrome (B&W) LCD	Color		
Resolution (pixels)	320 x 240				640x480	
Active Display Area W x H	76.7 x 57.5 mm (3.02 x 2.26 in.)	115.2 x 86.4 mm (4.54 x 3.40 in.)			153.7 x 115.8 mm (6.05 x 4.56 in.)	215.2 x 162.3 mm (8.43 x 6.39 in.)
Colors	8 levels of gray	16 gradations		4.096 colors		
Backlight (1)	LED Backlight (Color: Amber; Service life: 50,000 h. [half of original brightness]) (Color: Red; Service life: 10,000 h. [half of original brightness])	CFL Backlight (Service life: 58,000 h. at 25° C and continuous operation [half of original brightness])		CFL Backlight (Service life: 75,000 h. at 25° C and continuous operation [half of original brightness])	CFL Backlight (Service life: 54,000 h. at 25° C and continuous operation [half of original brightness])	CFL Backlight (Service life: 54,000 h. at 25° C and continuous operation [half of original brightness])
Contrast Adjustment	8 levels of adjustment available via touch panel.					
Brightness Adjustment	2 levels of adjustment for XBT GT1000 and 8 levels of adjustment for XBT GT1005 available via touch panel.	8 levels of adjustment available via touch panel.				
System Embedded Language Fonts (2)	ASCII: (Code page 850) Alphanumeric (including European characters) Chinese: (GB2312-80 codes) simplified Chinese fonts Japanese (except for XBT GT1000 series): ANK 158, Kanji: 6,962 (JIS Standards 1 & 2) (including 607 non-kanji characters) Korean: (KSC5601 - 1992 codes) Hangul fonts Taiwanese: (Big 5 codes) traditional Chinese fonts					

Specification	XBT GT1100 XBT GT1130 XBT GT1105 XBT GT1135	XBT GT2110	XBT GT2120 XBT GT2130 XBT GK2120	XBT GT2220	XBT GT4230	XBT GT5230
Character Sizes (2)	8 x 8, 8 x 16, 16 x 16 and 32 x 32 pixels fonts					
Font Sizes	Width can be expanded 1 to 8 times. Height can be expanded 1/2 and 1 to 8 times.					
8 x 8 pixels	40 Char. per row x 30 rows			80 Char. per row x 60 rows		
8 x 16 pixels	40 Char. per row x 15 rows			80 Char. per row x 30 rows		
16 x 16 pixels	20 Char. per row x 15 rows			40 Char. per row x 30 rows		
32 x 32 pixels	10 Char. per row x 7 rows			20 Char. per row x 15 rows		

NOTE: (1) Among backlight units there may be slight variations in illumination color, however, this does not affect the performance or quality of the unit.

(2) The display font will differ depending on which (language) character, or which size you select. Also, if Vijeo Designer 4.3 or later software is used, additional high quality fonts are available with 16 x 16 or larger characters.

TFT Displays

The following table describes the specification parameters of XBT GT 1335, XBT GT 2330, XBT GK 2330, XBT GH 2460, XBT GT 2430, XBT GH 2460 and XBT GT 2930.

Specification	XBT GT 1335	XBT GT 2330 XBT GK 2330 XBT GH 2460	XBT GT 2430	XBT GH 2460	XBT GT 2930
Type	TFT Color LCD				
Resolution (pixels)	320 x 240		640 x 480		320 x 240
Active Display Area W x H	76.7 x 57.5 mm (3.02 x 2.26 in.)		115.2 x 86.4 mm (4.54 x 3.40 in.)		117.2 x 88.4 mm (4.61 x 3.48 in.)
Colors	256 colors		65,536 colors		
Backlight (1)	CFL Backlight (Service life: 50,000 h. at 25° C and continuous operation [half of original brightness]) XBT GT2430, XBT GH2460: White LED Backlight (Service life: 50,000 hours or more at 25° C and continuous operation [period until backlight brightness decreases to 50% or backlight starts to flicker])				
Contrast Adjustment	8 levels of adjustment available via touch panel		Not available.		
Brightness Adjustment	8 levels of adjustment available via touch panel. XBT GH: 16 levels of adjustment available via touch panel.				

Specification	XBT GT 1335	XBT GT 2330 XBT GK 2330 XBT GH 2460	XBT GT 2430	XBT GH 2460	XBT GT 2930
System Embedded Language Fonts (2)	ASCII: (Code page 850) Alphanumeric (including European characters) Chinese: (GB2312-80 codes) simplified Chinese fonts Korean: (KSC5601 - 1992 codes) Hangul fonts Taiwanese: (Big 5 codes) traditional Chinese fonts XBT GH: Japanese: 6962 (JIS Standards 1 & 2) (including 607 non-kanji characters) ANK: 158 (Korean fonts, Simplified Chinese and Taiwanese, traditional Chinese fonts are downloadable)				
Character Sizes (2)	8 x 8, 8 x 16, 16 x 16 and 32 x 32 pixel fonts				
Font Sizes	Width can be expanded 1 to 8 times. Height can be expanded 1/2 and 1 to 8 times.				
8 x 8 pixels	40 Char. per row x 30 rows		80 Char. per row x 60 rows	40 Char. per row x 30 rows	
8 x 16 pixels	40 Char. per row x 15 rows		80 Char. per row x 30 rows	40 Char. per row x 15 rows	
16 x 16 pixels	20 Char. per row x 15 rows		40 Char. per row x 30 rows	20 Char. per row x 15 rows	
32 x 32 pixels	10 Char. per row x 7 rows		20 Char. per row x 15 rows	10 Char. per row x 7 rows	

The following table describes the specification parameters of XBT GT 4330, XBT GT 4340, XBT GT 5330, XBT GT 5340, XBT GK 5330, XBT GT 5430, XBT GT 6330, XBT GT 6340 and XBT GT 7340.

Specification	XBT GT 4330 XBT GT 4340	XBT GT 5330 XBT GT 5340 XBT GK 5330	XBT GT 5430	XBT GT 6330 XBT GT 6340	XBT GT 7340
Type	TFT Color LCD				
Resolution (pixels)	640 x 480		800 x 600	800 x 600	1024 x 768
Active Display Area W x H	153.7 x 115.8 mm (6.05 x 4.56 in.)	211.2 x 158.4 mm (8.31 x 6.24 in.)		248 x 186.5 mm (9.76 x 7.34 in.)	306.2 x 230.1 mm (12.06 x 9.06 in.)
Colors	65,536 colors				

Specification	XBT GT 4330 XBT GT 4340	XBT GT 5330 XBT GT 5340 XBT GK 5330	XBT GT 5430	XBT GT 6330 XBT GT 6340	XBT GT 7340
Backlight (1)	CFL Backlight (Service life: 54,000 h. at 25° C and continuous operation [half of original brightness])	CFL Backlight (Service life: 50,000 h. at 25° C and continuous operation [half of original brightness])		"XBTGT6330" RL 10 or higher and "XBTGT6340" RL 09 or higher: LED Backlight, "XBTGT6330"RL 9 or lower and "XBTGT6340" RL 08 or lower: CFL Backlight (Service life: 50,000 h. at 25° C and continuous operation [half of original brightness])	RL 09 or higher: LED Backlight, RL 08 or lower: CFL Backlight (Service life: 50,000 h. at 25° C and continuous operation [half of original brightness])
Contrast Adjustment	8 levels of adjustment available via touch panel	Not available.			
Brightness Adjustment	8 levels of adjustment available via touch panel.			16 levels of adjustment available via touch panel.	
System Embedded Language Fonts (2)	ASCII: (Code page 850) Alphanumeric (including European characters) Chinese: (GB2312-80 codes) simplified Chinese fonts Korean: (KSC5601 - 1992 codes) Hangul fonts Taiwanese: (Big 5 codes) traditional Chinese fonts				
Character Sizes (2)	8 x 8, 8 x 16, 16 x 16 and 32 x 32 pixel fonts				
Font Sizes	Width can be expanded 1 to 8 times. Height can be expanded 1/2 and 1 to 8 times.				
8 x 8 pixels	80 Char. per row x 60 rows		100 Char. per row x 75 rows		128 Char. per row x 96 rows
8 x 16 pixels	80 Char. per row x 30 rows		100 Char. per row x 37 rows		128 Char. per row x 48 rows
16 x 16 pixels	40 Char. per row x 30 rows		50 Char. per row x 37 rows		64 Char. per row x 48 rows
32 x 32 pixels	20 Char. per row x 15 rows		25 Char. per row x 18 rows		32 Char. per row x 24rows

NOTE: (1) Among backlight units there may be slight variations in illumination color, however, this does not affect the performance or quality of the unit.

(2) The display font will differ depending on which (language) character, or which size you select. Also, if Vijeo Designer 4.3 or later software is used, additional high quality fonts are available with 16 x 16 or larger characters.

Display Viewing Angle and Brightness

Model	Viewing angle									Brightness		
	Upper		Lower		Left		Right		Unit	Contrast (CR)	Actual Products	
	Min	Typ	Min	Typ	Min	Typ	Min	Typ			Typ	Unit
XBT GT1100	20	-	30	-	40	-	40	-	degrees	CR≥2	87/51	cd/m2
XBT GT1130												
XBT GT1105												
XBT GT1135												
XBT GT1335												
XBT GT2110	20	-	40	-	45	-	45	-	degrees	CR≥2	216	cd/m2
XBT GT2120												
XBT GT2130												
XBT GT2220	-	65	-	70	-	55	-	55	degrees	CR≥2	298	cd/m2
XBT GT2330	60	65	35	40	60	65	60	65	degrees	CR≥5	422	cd/m2
XBT GT2430	-	80	-	70	-	80	-	80	degrees	CR≥5	400	cd/m2
XBT GT2930	-	70	-	50	-	70	-	70	degrees	CR≥5	1000	cd/m2
XBT GT4230	-	20	-	40	-	40	-	40	degrees	CR≥2	167	cd/m2
XBT GT4330	-	50	-	70	-	70	-	70	degrees	CR≥5	213	cd/m2
XBT GT4340												
XBT GT5230	-	20	-	35	-	45	-	45	degrees	CR≥2	172	cd/m2
XBT GT5330	35	40	55	70	60	70	60	70	degrees	CR≥10	311	cd/m2
XBT GT5340												
XBT GT5430	35	50	55	60	60	70	60	70			390	cd/m2
XBT GT6330	30	50	40	70	45	70	45	70	degrees	CR≥10	170	cd/m2
XBT GT6340												
XBT GT7340	60	75	50	55	60	80	60	80	degrees	CR≥2	220	cd/m2
XBT GK2120	20	-	40	-	45	-	45	-	degrees	CR≥2	216	cd/m2
XBT GK2330	60	65	35	40	60	65	60	65	degrees	CR≥5	422	cd/m2
XBT GK5330	35	40	55	70	60	70	60	70	degrees	CR≥10	311	cd/m2
XBT GH2460	-	80	-	70	-	80	-	80	degrees	CR≥5	189	cd/m2

The definition of viewing angle:

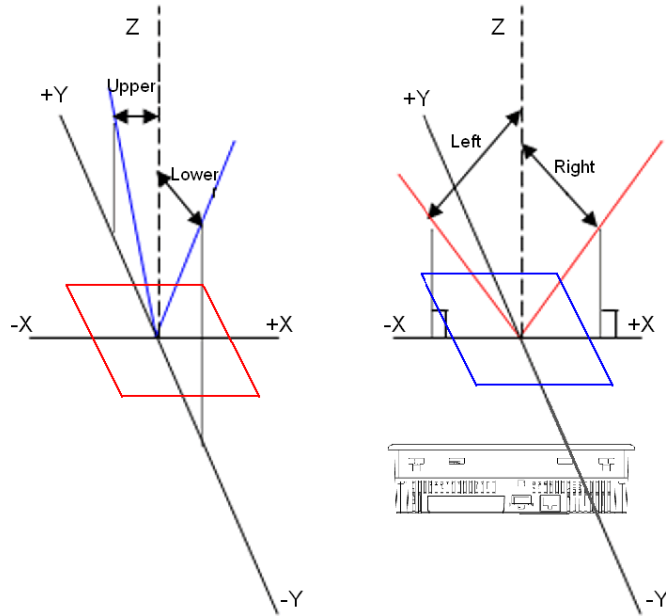

Memory, Clock, and Touch Panel

Memory

The following table describes the memory parameters of XBT GT1100, XBT GT1130, XBT GT1105, XBT GT1135, XBT GT1335, XBT GT2110, XBT GT2120, XBT GT2130, XBT GT2220, XBT GT2330, XBT GT2930, XBT GK2120 and XBT GK2330.

Memory	XBT GT1100 XBT GT1130	XBT GT1105 XBT GT1135 XBT GT1335	XBT GT2110	XBT GT2120 XBT GT2130 XBT GT2220 XBT GT2330 XBT GT2930 XBT GK2120 XBT GK2330
Application Flash EPROM	8 MB	32 MB	16 MB	16 MB
Data Backup SRAM uses a lithium battery (1)	512 KB	512 KB	128 KB	512 KB
Application run DRAM	16 MB	16 MB	32 MB	32 MB
Legend: (1) A lithium battery life is: <ul style="list-style-type: none"> • 10 years when the battery's ambient temperature is $\leq 40^{\circ}\text{C}$ (104°F). • 10 years when the unit's ambient temperature is $\leq 25^{\circ}\text{C}$ (77°F). When used for backup (without main power): <ul style="list-style-type: none"> • Approximately 60 days, with a fully charged battery. • Approximately 6 days, with a 10% charged battery. 				

The following table describes the memory parameters of XBT GT2430, XBT GT4230, XBT GT4330, XBT GT5230, XBT GT5330, XBT GT5430, XBT GT6330, XBT GK5330, XBT GT4340, XBT GT5340, XBT GT6340, XBT GT7340 and XBT GH2460.

Memory	XBT GT2430	XBT GT4230 XBT GT4330 XBT GT5230 XBT GT5330 XBT GT5430 XBT GT6330 XBT GK5330	XBT GT4340 XBT GT5340 XBT GT6340 XBT GT7340 XBT GH2460
Application Flash EPROM	32 MB	32 MB	32 MB
Data Backup SRAM uses a lithium battery (1)	512 KB	512 KB	512 KB
Application run DRAM	64 MB	32 MB	64 MB

Memory	XBT GT2430	XBT GT4230 XBT GT4330 XBT GT5230 XBT GT5330 XBT GT5430 XBT GT6330 XBT GK5330	XBT GT4340 XBT GT5340 XBT GT6340 XBT GT7340 XBT GH2460
---------------	-------------------	---	---

Legend:

(1) A lithium battery life is:

- 10 years when the battery's ambient temperature is ≤ 40 °C (104 °F).
- 10 years when the unit's ambient temperature is ≤ 25 °C (77 °F).

When used for backup (without main power):

- Approximately 60 days, with a fully charged battery.
- Approximately 6 days, with a 10% charged battery.

NOTE:

The XBTGT5430 model is offered with two different amounts of DRAM:

- 32 MB for target machines with PV: 01, RL: 00, SV: 1.0
- 64 MB for target machines with PV: 01, RL: 01, SV: 1.1

When you build an application for the XBTGT5430 model, DRAM usage is based on 64 MB of DRAM. No additional memory check is performed if you are using the 32 MB version. Make sure your application does not exceed the amount of DRAM available on your target machine. To find out the amount of memory available on target machines, in the Vijeo Designer online help search for the topic **Displaying Memory**.

Clock

Variations in operating conditions and battery life can cause a clock error from -380 to +90 seconds per month.

Monitor and adjust the time as needed to satisfy the system requirements. For time-dependent applications, refer to the Vijeo Designer Help for information on synchronizing the unit's clock with the PLC clock. To preserve processing time, do not synchronize continually. The clocks can be synchronized approximately twice/day.

Touch Panel and Function Keys

Specification	XBT GT1000	XBT GT1005/2000/4000/5000/6000/7000 series
Touch panel resolution	8 x 6 matrix 1 or 2 point push, selectable	Analog typing system 1024 x 1024 resolution, (single point push selectable)
Function keys	6	-
Service Life	More than 1,000,000 actions	

Specification	XBT GH2000 series
Touch panel resolution	Analog typing system 1024 x 1024 resolution, (single point push selectable)
Dynamic Function keys (Ri)	11 (F1~F11)
Service Life	More than 1,000,000 actions

Specification	XBT GK2000 series	XBT GK5000 series
Touch panel resolution	Analog typing system 1024 x 1024 resolution, (single point push selectable)	
Static Function keys (Fi)	10	12
Dynamic Function keys (Ri)	14	18
Service Life	More than 1,000,000 actions	

XBT GK/GH Function Keys

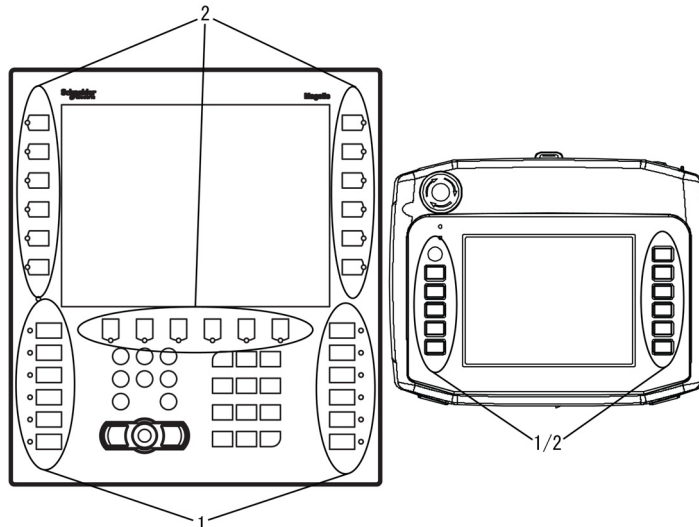

- 1 Static Function Keys
- 2 Dynamic Function Keys

NOTE: Static keys (Fi) can be customized by printing text or pictograms on the insert labels using label design templates in Vijeo Designer. Dynamic keys (Ri) can be linked to labels or images on the screen using tools in Vijeo Designer.

Industrial Pointer, Keypads, Switches and LEDs

Introduction

XBT GK and XBT GH units contain several features in addition to the touch screen panel. XBT GK units come with an industrial pointer device and keypads. They are useful for environments where touch screen applications are inappropriate. For example, operators who handle abrasive or corrosive material may damage displays due to the residue left on their fingers or gloves. The pointer and keypad provide an alternate method of interacting with the units.

Industrial Pointer Device

The industrial pointer device moves a pointer on the panel. When the pointer is positioned over an object, you can click the pointer button to interact with the object. Clicking an object with the pointer has the same effect as touching it on the panel with your finger. The pointer changes shape when positioned over an active object or area.

All XBT GK units have 2 pointer buttons. They both have the same effect, so you can use either one, for example, in the case of left-handed or right-handed operators.

An operator can interact with the unit in one of four ways:

- Industrial Pointer Device only
- Touch-screen only
- Both
- Neither Touch-screen nor Industrial Pointer Device. Interaction with the unit is only possible through the function keys.

You specify how an operator interacts with the unit in Vijeo Designer.

Keypads

Besides function keys (static and dynamic), XBT GK units come with an alphanumeric keypad to facilitate operator input. The alphanumeric keypad consists of two parts: the cursor keys and the alphanumeric keys.

Cursor Keys

Key	Description
Backspace ←	Deletes the digit to the left of the cursor position in a data input field.
Esc	Removes the cursor from a data input field without modifying the previous value.
Enter	Validates data entered into a data input field.

Key	Description
Clr (Shift + Back Space)	Deletes everything in the active data input field.
System (Shift + Esc)	To open the system configuration panel with (Shift + Esc), refer to Vijeo Designer Online Help. By default, this function is not enabled.
Print (Shift + Enter)	To take a snapshot of the current panel with (Shift + Enter), refer to the Screen Snapshot function in the Vijeo Designer Online Help. By default, this function is not enabled.
Increment ▲	<ul style="list-style-type: none"> ● Sets the focus from one object to another in a list of objects ● Increases or decreases the variable value in a graphical tool or object ● Increases or decreases the numerical value in a numerical input field
Decrement ▼	
◀	Moves the cursor left or right in a data input field.
▶	

Alphanumeric Keys

Key	Shift + Key	Description
7ABC	7abc	Each key press cycles through the characters available for the key. The characters available depend on the display format of the field you are editing. For example, a Numeric Display supports decimal, hexadecimal, octal, and binary display formats. See the Vijeo Designer Online Help for more information on display formats.
8DEF	8def	
9GHI	9ghi	
4JKL	4jkl	
5MNO	5mno	
6PQR	6pqr	
1STU	1stu	
2VWX	2vwx	
3YZ_	3yz_	
+/-	+/-	
0	0	
.	.	

Fine Tuning

For numerical values in a data input field, use the Increment and Decrement keys on the edition keypad to increase or decrease the value. The fine tuning feature controls the rate at which the value increases or decreases. The following examples show how to use fine tuning with the Increment key, but work exactly the same for the Decrement key as well.

- Each press of the Increment key increases the value by one, to the next least significant digit. For example, after a key press, the value 2 increments to 3, after a second key press, the value increments to 4, and so on.
- Press and hold the key to increment the value automatically. The value increases by the least significant digit as before.
- Continue to hold the key:
 - After ten increments, the value starts to increase in multiples of 10. For example, the value 12 increments to 22, then 32, then 42, and so on.
 - After 10 more increments, the value increases in multiples of 100. For example, the value 112 becomes 212, 312, 412, and so on.
 - 10 increments more, and the value increase in multiples of 1000. For example, the value 1112 becomes 2112, 3112, 4112, and so on. This is the highest increment rate.
 - When you reach the maximum value specified for the data input, the Increment key becomes inactive.
- Release the Increment key to go back to increasing the value by one. Hold the key again to restart the fine tuning feature.

LEDs

Each function key has a corresponding LED. The behavior of the LEDs are programmed at the application level. For example, a LED can start blinking to highlight possible choices or indicate ongoing action as determined by the PLC.

LEDs can light up in one of three colors: orange, red, and green.

LEDs can be in one of four states: off, steady on, blinking (about 1 Hz), fast blinking (>1 Hz).

Key Switch

Turn on and turn off the XBT GH unit by turning the key switch.

Specifications	
Key Switch Output Interface	1c-contact (can be set normally open or normally closed) Rated voltage: 24 Vdc Maximum rated current: 300 mA

Operation Switch

XBT GH units only accept touch panel and function key inputs when the operation switch is pressed.

Emergency Switch

The emergency switch on XBT GH units activates the contact output when the emergency switch is enabled. To reset the emergency stop status (lock status), pull the button forward, or turn the button in the direction indicated by the arrows on the switch. The emergency switch complies with Safety Category (ISO 13849-1).

Specifications	
Emergency Switch Output Interface	Push-lock switch 3 contacts: a-contact (normally open): 1 contact b-contact (normally closed): 2 contacts Rated voltage: 30 Vdc Maximum rated current: 1 A (Minimum allowable load: 5 Vdc, 1 mA) Applicable standards: <ul style="list-style-type: none">● ICE 60947-5-1● EN 60947-5-1● ICE 60947-5-5● EN 60947-5-5● UL 508● CSA C22.2 No. 14

3-Position Enable Switch

The 3-position enable switch on XBT GH units has three positions: the released position where the switch is not depressed, the half-depressed position, and the fully depressed position (fully closed).

Specifications	
3-Position Enable Switch Output Interface	GH Rear Panel Switch 2 contacts (a-contact: normally open) Rated voltage: 30 Vdc Maximum rated current: 700 mA (Minimum allowable load: 3 Vdc, 5 mA) Applicable standards: <ul style="list-style-type: none">● ICE 60947-5-8● EN 60947-5-8● UL 508 (UL approval)● CSA C22.2 No. 14 (UL approval)● ISO 12100/EN 12100-1, 2● IEC 60204-1 / EN 60204-1● ISO 11161 / prEN 11161● ISO 10218/EN 775● ANSI / RIA R15.06● ANSI B11.19

Be aware of the maximum and minimum permitted current load of the Emergency Stop button, the Key Switch, and the Enable Switch. Incorrect current load can damage important safety components or cause emergency functions to fail.

WARNING

LOSS OF CONTROL

Never operate the XBT GH device while any of its emergency functions are inoperative.

Failure to follow these instructions can result in death, serious injury, or equipment damage.

Insert Labels XBT GK and XBT GH

Overview

XBT GKs and XBT GHs are delivered with an insert label sheet providing the following label types to assign different texts or symbols to the function keys:

- function key labels
- blank labels

All labels are pre-cut and just have to be pressed out of the label sheet.

The ready-to-use function key labels can directly be inserted into the XBT GK and XBT GH as described below (*see page 57*).

Printing Insert Labels

You can print our your own text or symbols on the blank labels. Make sure to remove the protective layer from the label sheet before printing. To print your own lables, use Vijeo Designer and one of the following laser printers:

- Laser printer Epson 6200L
- Copier Lexmark X852e

WARNING

UNINTENDED EQUIPMENT OPERATION

Make sure that the text/symbols on your insert label always correspond to what is configured for the XBT GK or XBT GH in Vijeo Designer. Otherwise the keys of your unit will not initiate the actions indicated on them.

Failure to follow these instructions can result in death, serious injury, or equipment damage.

Inserting Insert Labels

CAUTION

WATER DAMAGE

Be sure to insert the labels properly and slide the flap correctly into the chassis slit. Do not pinch the flap between the product and the panel.

Failure to follow these instructions can result in injury or equipment damage.

Insert the labels into the device carefully. Make sure that they indicate the correct functions on the panel. The labels can be replaced as needed.

Graphical Representation of Correctly Inserting Labels into the XBT GK

The following describes the procedures of inserting insert labels into the XBT GK.

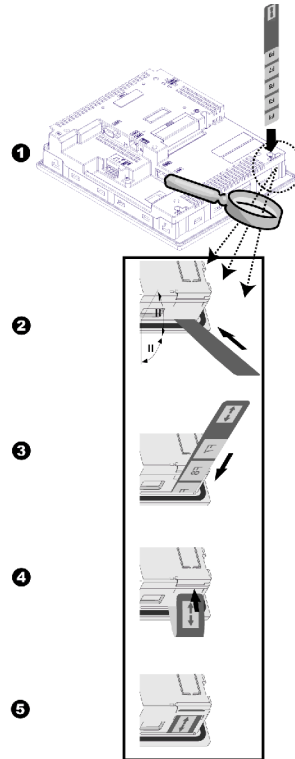

Inserting Labels into the XBT GK

Step	Action
1	Press the pre-cut insert label of your choice out of the insert label sheet.
2	Remove the XBT GK from any enclosures or mounts. Take the XBT GK and turn it around so that you can see its rear panel. At the bottom two corners of the rear panel, located directly behind the overlapping display, you will find the opening for the insert label.
3	Insert the insert label cautiously into this opening (as shown in the above figure) until the key symbols / text on the wide part of the insert labels have disappeared and the wide part of the insert label is flush with the opening. There will be merely the small flap of the insert label with the double arrow being visible outside the unit.

Step	Action
4	Turn the XBT GK around and check the front that all symbols / text are clearly visible at the keys. If the text / symbols are not clearly visible, insert the insert label a bit further into the opening.
5	If the text / symbols are clearly visible on the front of the unit, take the small part (with the double arrow sign) of the insert label that is still visible on the rear of the unit and slide this flap into the slit. The flap should now be flush with the rear of the unit. If the insert label has not correctly been inserted into the XBT GK, the flap of the insert label will be too long to fit into this slit.

Graphical Representation of Correctly Inserting Labels into the XBT GH

The following describes the procedures of inserting insert labels into the XBT GH.

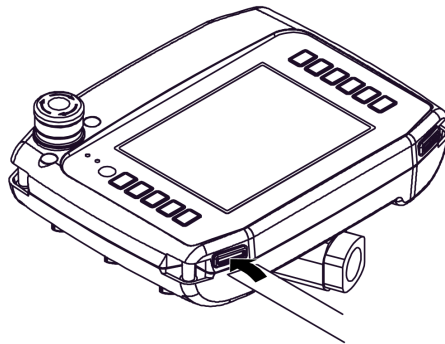

Inserting Labels into the XBT GH

Step	Action
1	Press the pre-cut insert label of your choice out of the insert label sheet.
2	Take the XBT GH and turn it up so that you can see its bottom panel. On the lower right and left corners, you will find the opening for the insert label.
3	Remove the cover on the insertion hole and insert the insert label cautiously all the way into this opening (as shown in the above figure).
4	Check the front panel of the XBT GH that all symbols / text are clearly visible at the keys. If the text / symbols are not clearly visible, insert the insert label a bit further into the opening.
5	If the text / symbols are clearly visible on the front of the unit, put the cover back on the insertion hold. If the insert label has not correctly been inserted into the XBT GH, the cover cannot be pressed into place.

Serial Interface

Introduction

All XBT GT, XBT GK, and XBT GH displays are provided with a serial interface and tool port or USB Interface.

Serial Tool Port

The following table describes the tool port of XBT GT1100/1130

Interface	Description
Tool Port	Asynchronous TTL level nonprocedural interface command. Used for transferring data user program to and from Vijeo Designer and XBT GT.

Serial Interface COM1

The following table describes the serial interface COM1 of XBT GT1100/1130 series units.

Interface	Description
Serial interface COM1 RJ45	
Asynchronous Transmission	RS-232C / RS-422
Data Length	7 or 8 bits
Stop Bit	1 or 2 bits
Parity	None, odd or even
Data Transmission Speed	2,400 to 115,200 bps

The following table describes the serial interface COM1 of XBT GT 1005 series units.

Interface	Description
Serial interface COM1 RJ45	
Asynchronous Transmission	RS-232C / RS-485
Data Length	7 or 8 bits
Stop Bit	1 or 2 bits
Parity	None, odd or even
Data Transmission Speed	2,400 to 115,200 bps

The following table lists the serial interface COM1 of XBT GT2000/4000/5000/6000/7000 and XBT GK series units, and COM on the XBT GH series units.

Interface	Description
Serial interface COM/COM1 D-Sub9	
Asynchronous Transmission	RS-232C / RS-422-485
Data Length	7 or 8 bits
Stop Bit	1 or 2 bits
Parity	None, odd or even
Data Transmission Speed	2,400 to 115,200 bps

Serial Interface COM2

The following table lists the serial interface COM2 of XBT GT2000/4000/5000/6000/7000 and XBT GK series units.

Interface	Description
Serial interface COM2 RJ45	
Asynchronous Transmission	RS-485
Data Length	7 or 8 bits
Stop Bit	1 or 2 bits
Parity	None, odd or even
Data Transmission Speed	2,400 bps to 187.5Kbps

Ethernet Interface

The following table lists the serial interface Ethernet available for XBT GT series, XBT GK series, and XBT GH series:

Interface	Description
Ethernet RJ45	IEEE 802.3, 10Base-T/100Base-TX (except for XBT GT1100/1105/2110/2120/2220 and XBT GK2120: none, and XBT GT1130: 10Base-T.)

USB Interface and Memory Card

The following table lists the serial interface USB and memory card available for XBT GT, XBT GK, and XBT GH series:

Interface	Description
USB TYPE-A	USB 1.1 host I/F
CF card slot (TYPE-II (except XBT GT1100/1130/1105/1135/1335/2110))	Compact Flash

3.3 Interface Specifications

Overview

This section presents the interface specifications of the units.

What Is in This Section?

This section contains the following topics:

Topic	Page
Specifications of Serial Interface COM1/COM	64
Specifications of Serial Interface COM2	68
Other Interfaces	69

Specifications of Serial Interface COM1/COM

Introduction

This interface is used to connect:

- XBT GT1000/1005 series to remote equipment, via an RS-232C or RS-485 cable. The connector used is a RJ45-type connector.
- XBT GT2000/4000/5000/6000/7000 series to remote equipment, via an RS-232C or RS-422-485 cable. The connector used is a 9-pin SUB-D connector.
- XBT GK series to remote equipment, via an RS-232C or RS-422-485 cable. The connector used is a 9-pin SUB-D connector.
- XBT GH series to remote equipment, via an RS-232C or RS-422-485 cable. The connector used is a 9-pin SUB-D connector.

When using a long PLC cable to connect to the unit, it is possible the cable can be at a different electrical potential than the unit, even if both are connected to ground.

The unit's serial port is not isolated. The SG (signal ground) and the FG (frame ground) terminals are connected inside the unit.

DANGER

ELECTRIC SHOCK

- Make a direct connection between the frame ground (FG) terminal and ground.
- Do not connect other devices to ground through the frame ground (FG) terminal of this device.
- Install all cables according to local codes and requirements. If local codes do not require grounding, follow a reliable guide such as the US National Electrical Code, Article 800.

Failure to follow these instructions will result in death or serious injury.

XBT GT1000/1005 Series Serial Interface COM1

This interface is used to connect a RS-232C/RS-485 serial cable. An RJ45 8-pin plug connector is used.

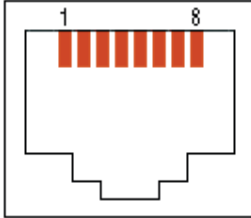
Pin Connection	Pin	Signal Name	Direction	Meaning
<p style="text-align: center;">Front</p> 	1	RXD	Input	Receive Data (RS-232C)
	2	TXD	Output	Send Data (RS-232C)
	3	Not connected	-	-
	4	D1	Output/Input	Transfer Data (RS-485)
	5	D0	Output/Input	Transfer Data (RS-485)
	6	RTS	Output	Request To Send
	7	Not connected	-	-
	8	SG	-	Signal Ground

Any excessive weight or stress on communication cables may cause an equipment's disconnection and unintended equipment operation.

⚠ CAUTION

LOSS OF POWER

- All connections to the communication ports on the bottom and sides of the unit must not put excessive stress on the ports.
- Securely attach communication cables to the panel or cabinet.
- Use only RJ45 cables with a locking tab in good condition.
- Use RJ45 connectors with locking system.

Failure to follow these instructions can result in injury or equipment damage.

XBT GT2000/4000/5000/6000/7000, XBT GK series Serial Interface COM1, XBT GH COM

The following table describes the serial interface with a 9-pin SUB-D connector via an RS-232C cable.

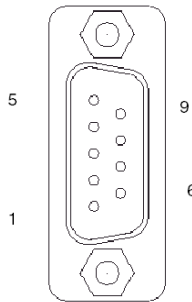
Pin Connection	Pin	Signal Name	Direction	Meaning
	1	CD	Input	Carrier Detect
	2	RD(RXD)	Input	Receive Data
	3	SD(TXD)	Output	Send Data
	4	ER(DTR)	Output	Data Terminal Ready
	5	SG	-	Signal Ground
	6	DR(DSR)	Input	Data Set Ready
	7	RS(RTS)	Output	Request to Send
	8	CS(CTS)	Input	Send Possible
	9	CI(RI)/VCC	Input	Called status display/+5V5% Output 0.25A
	Shell	FG	-	Frame Ground (Common with SG)

The following table describes the serial interface with a 9-pin SUB-D connector via an RS-422/RS-485 cable.

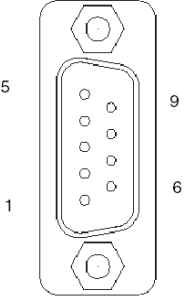
Pin Connection	Pin	Signal Name	Direction	Meaning
	1	RDA	Input	Receive Data A (+)
	2	RDB	Input	Receive Data B (-)
	3	SDA	Output	Send Data A (+)
	4	ERA	Output	Data Terminal Ready A (+)
	5	SG	-	Signal Ground
	6	CSB	Input	Send Possible B (-)
	7	SDB	Output	Send Data B (-)
	8	CSA	Input	Send Possible (A)
	9	ERB	Output	Data Terminal Ready B (-)
	Shell	FG	-	Frame Ground (Common with SG)

Any excessive weight or stress on communication cables may cause an equipment's disconnection.

 **CAUTION**

LOSS OF POWER

- All connections to the communication ports on the bottom and sides of the unit must not put excessive stress on the ports.
- Securely attach communication cables to the panel or cabinet.
- Use only 9-pin SUB-D cables with a locking system in good condition.

Failure to follow these instructions can result in injury or equipment damage.

Specifications of Serial Interface COM2

Introduction

This interface is used to connect the XBT GT2000/4000/5000/6000/7000 and XBT GK series to the remote equipment, via RS-485 cable. The connector used is a RJ45-8-pin type connector.

The unit's Serial Port is not isolated. The SG (signal ground) and FG (frame ground) terminals are connected inside the unit.

⚠ DANGER

ELECTRIC SHOCK

- Make a direct connection between the frame ground (FG) terminal and ground.
- Do not connect other devices to ground through the frame ground (FG) terminal of this device.

Failure to follow these instructions will result in death or serious injury.

Serial Interface COM2 with RS-485 cable

This interface is used to connect a RS-485 serial cable to a XBT GT2000/4000/5000/6000/7000 or XBT GK series unit. RJ45 8-pin plug connector is used.

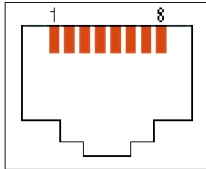
Pin Connection	Pin	Signal Name	Direction	Meaning
<div style="text-align: center;">Front </div>	1	Not connected	-	-
	2	Not connected	-	-
	3	Not connected	-	-
	4	D1	Output/Input	Transfer Data (RS-485)
	5	D0	Output/Input	Transfer Data (RS-485)
	6	RTS	Output	Request To Send
	7	Not connected	-	-
	8	SG	-	Signal Ground

Other Interfaces

Ethernet Interface

The Ethernet Interface is used for the following units:

- XBT GT1130
- XBT GT1135
- XBT GT1335
- XBT GT2130
- XBT GT2330
- XBT GT2430
- XBT GT2930
- XBT GT4000 series
- XBT GT5000 series
- XBT GT6000 series
- XBT GT7000 series
- XBT GK2330
- XBT GK5330
- XBT GH2460

This interface complies with the IEEE 802.3 standard for Ethernet:

- 10Base-T (XBT GT1000)
- 10Base-T/100Base-TX (XBT GT1005/2000/4000/5000/6000/7000, XBT GK, and XBT GH series) connections.

The following table describes the LED colors and status for all target machines except the XBT GT1135, XBT GT1335 and XBT GT6330:

LED	Contents
Orange	<ul style="list-style-type: none">● When the power supply is ON: LED lights up.● When sending or receiving: LED blinks.
Green	When linking: LED lights up.

The following table describes the LED colors and status for the XBT GT1135, XBT GT1335 and XBT GT6330:

	XBT GT1135 XBT GT1335		XBT GT6330	
Connection	Green LED	Orange LED	Green LED	Orange LED
Disconnected	Off	Off	Off	Off
HUB 100 Mbps	On / Flashing	Off	On	Flashing
HUB 10 Mbps	On / Flashing	Off	On	Flashing
Switch 10 Mbps HDX	On / Flashing	Off	On	Flashing
Switch 10 Mbps FDX	On / Flashing	Off	On	Flashing

	XBT GT1135 XBT GT1335		XBT GT6330	
Connection	Green LED	Orange LED	Green LED	Orange LED
Switch 100 Mbps HDX	On / Flashing	Off	On	Flashing
Switch 100 Mbps FDX	On / Flashing	Off	On	Flashing
Switch Auto	On / Flashing	On	On	Flashing

USB Interface

The USB Interface accepts a USB data transfer cable and is used for the following units:

- XBT GT1005 series
- XBT GT2000 series
- XBT GT4000 series
- XBT GT5000 series
- XBT GT6000 series
- XBT GT7000 series
- XBT GK series
- XBT GH series

Sound Output/AUX Input/Output Interface for XBT GT 4000/5000/6000/7000 Series and XBT GK 5330

The following table describes the output interface specifications for the AUX Port:

Sound Output Interface	Speaker output: 70 mW (rated load: 8W, frequency:1 KHz) Connector: two piece type terminal block
	XBT GT2430 speaker output: 70mW (rated load: 8 Ω) Connector: MINI-JACK 3.5 mm (0.13 in.) Audio characteristics: Harmonic distortion: 5 % max. Bandwidth: 100 Hz ~ 2 KHz
AUX Input/Output Interface	Alarm output, RUN output; buzzer output: Rated voltage: 24 Vdc Rated current: 50 mA
	Remote reset input: Input voltage: 2 Vdc Input current: 6 mA Operating voltage: (when ON) minimum 9 Vdc, (when OFF) maximum 2.5 Vdc Connector: two piece type terminal block

This interface is used for external reset, alarm output, buzzer output or sound output.

Pin Connection	Pin	Signal Name	Direction	Meaning
	1	RESET IN_A	Input	External reset input
	2	RESET IN_B	Input	
	3	RUN+	Output	RUN signal
	4	RUN-	Output	
	5	ALARM+	Output	ALARM signal
	6	ALARM-	Output	
	7	BUZZER+	Output	Buzzer signal
	8	BUZZER-	Output	
	9	NC	-	Not connected
	10	NC	-	Not connected
	11	SP	Output	Speaker out
	12	SP_GROUND	Output	Speaker ground

Input Circuit

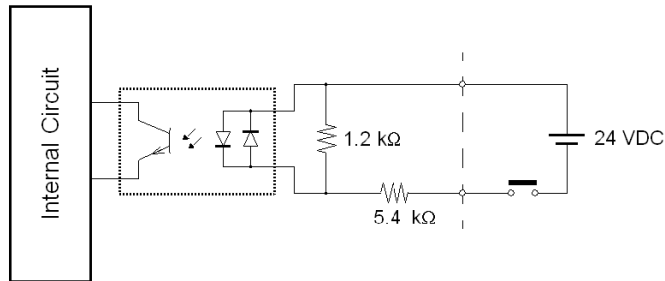

Output Circuit

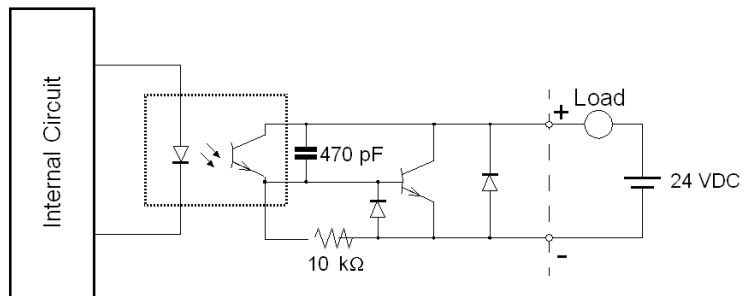

3.4 Part Numbers and Functions

Overview

This section presents the Part Number and Functions of XBT GT, and XBT GH units.

What Is in This Section?

This section contains the following topics:

Topic	Page
Parts Identification and Functions	73
Terminal Configuration Switches	104

Parts Identification and Functions

XBT GT1100 and XBT GT1130

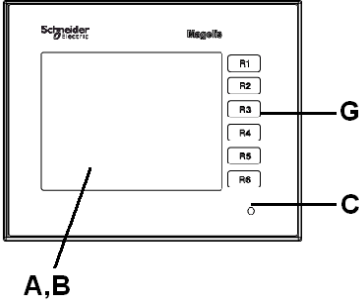
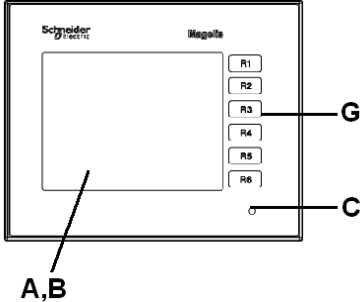
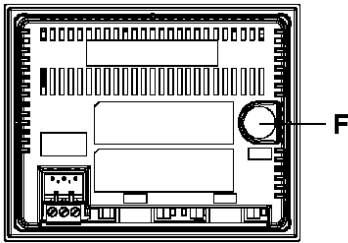
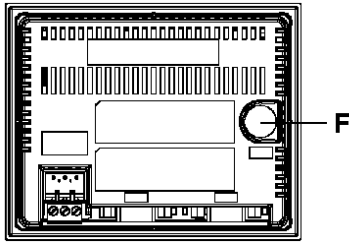
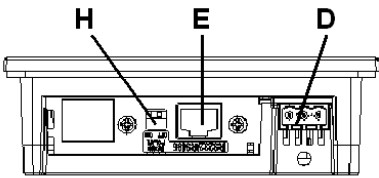
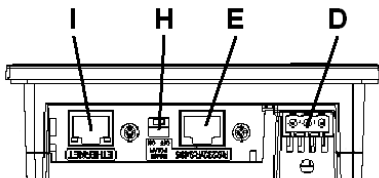
Side	XBT GT1100	XBT GT1130
Front	 <p>Diagram showing the front view of the XBT GT1100 terminal block. It features a central display area labeled 'A,B' and a row of six terminals labeled R1 through R6. A small switch is located below the terminals, labeled 'C'. The Schneider Electric logo and 'Megolla' brand name are visible at the top.</p>	 <p>Diagram showing the front view of the XBT GT1130 terminal block. It features a central display area labeled 'A,B' and a row of six terminals labeled R1 through R6. A small switch is located below the terminals, labeled 'C'. The Schneider Electric logo and 'Megolla' brand name are visible at the top.</p>
Rear	 <p>Diagram showing the rear view of the XBT GT1100 terminal block. A circular component is labeled 'F'.</p>	 <p>Diagram showing the rear view of the XBT GT1130 terminal block. A circular component is labeled 'F'.</p>
Bottom	 <p>Diagram showing the bottom view of the XBT GT1100 terminal block. Three components are labeled: 'H' (left), 'E' (middle), and 'D' (right).</p>	 <p>Diagram showing the bottom view of the XBT GT1130 terminal block. Four components are labeled: 'I' (left), 'H' (second from left), 'E' (middle), and 'D' (right).</p>

Part	Description
A	Display: displays user created screens and remote equipment variables.
B	Touch panel: performs screen change operations and sends data to the host (PLC).
C	Status LED
D	Power input Terminal block: connects the XBT GT power cable's input and ground wires to the XBT GT.
E	Serial I/F (host I/F 8 pin RJ-45): connects a RS-232C or RS-485 (serial) cable (from the host/PLC) to the XBT GT (Y port).
F	Tool port connector: connects the Data Transfer Cable to the XBT GT.
G	Function switches (R1 to R6): used for function keys.
H	RS-485 Line Polarization Selector Switch.
I	Ethernet Interface (LAN) (except for XBT GT1100): permits to connect the XBT GT unit (X port) to PLC from a Ethernet cable.

XBT GT1005 Series

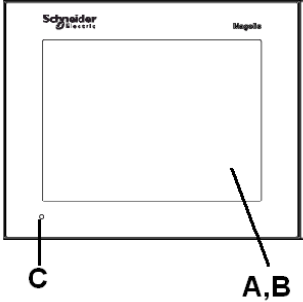
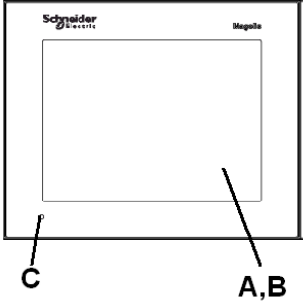
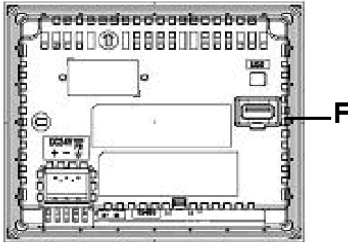
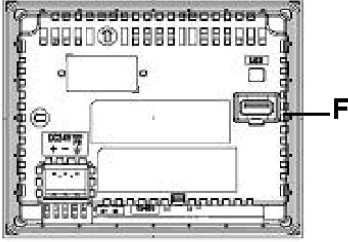
Side	XBT GT1105	XBT GT1135/1335
Front	 <p>Diagram of the front view of the XBT GT1105 terminal block. It shows a central rectangular display area labeled 'A,B' and a small circular status LED on the left side labeled 'C'. The top of the unit features the 'Schneider Magella' logo.</p>	 <p>Diagram of the front view of the XBT GT1135/1335 terminal block. It shows a central rectangular display area labeled 'A,B' and a small circular status LED on the left side labeled 'C'. The top of the unit features the 'Schneider Magella' logo.</p>
Rear	 <p>Diagram of the rear view of the XBT GT1105 terminal block. It shows a complex arrangement of ports and connectors. A specific port on the right side is labeled 'F', which is the tool port connector.</p>	 <p>Diagram of the rear view of the XBT GT1135/1335 terminal block. It shows a complex arrangement of ports and connectors. A specific port on the right side is labeled 'F', which is the tool port connector.</p>

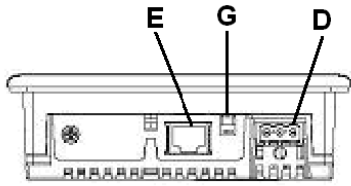
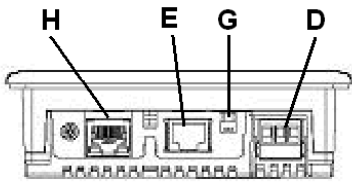
Side	XBT GT1105	XBT GT1135/1335
Bottom		

Part	Description
A	Display: displays user created screens and remote equipment variables.
B	Touch panel: performs screen change operations and sends data to the host (PLC).
C	Status LED
D	Power input Terminal block: connects the XBT GT power cable's input and ground wires to the XBT GT.
E	Serial I/F (host I/F 8 pin RJ-45): connects a RS-232C or RS-485 (serial) cable (from the host/PLC) to the XBT GT (Y port).
F	USB interface (USB1.1): connects a data transfer cable or peripherals or PLC USB terminal port to XBT GT.
G	RS-485 Line Polarization Selector Switch.
H	Ethernet interface (LAN) (10Base-T/100Base-TX) (except XBT GT1105): RJ-45 connector is used, and the LEDs turn ON or OFF to indicate the current status. <ul style="list-style-type: none"> ● Green ON: Data transmission available. ● Green Flashing: Data is transmitting. ● Green OFF: No connection or loss of communication. ● Yellow ON: Connected to 100BASE-TX. ● Yellow OFF: Connected to 10BASE-T or No connection.

XBT GT2000 Series

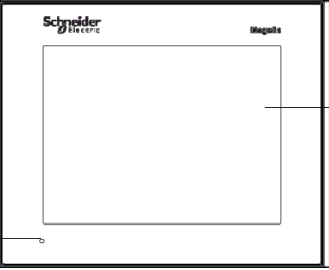
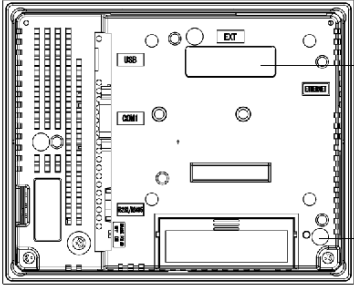
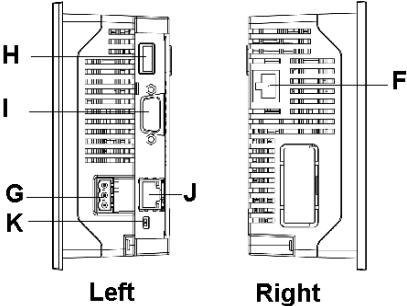
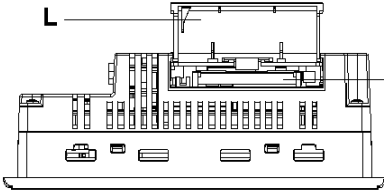
Side	XBT GT2000 series Part Identification
Front	
Rear	
Left and Right	
CF Card Cover Open	

Part	Description
A	Display: displays user created screens and remote equipment variables.
B	Touch panel: performs screen change operations and sends data to the host (PLC).
C	Status LED: <ul style="list-style-type: none"> ● Green (steady): normal operation (power is ON) or OFFLINE operation. ● Orange (steady): backlight burnout is detected. ● Orange (blinking): during software startup. ● Red (steady): when power is turned ON. ● Not lit: power is OFF.
D	Expansion unit interface: connects expansion units with communication features.
E	CF card access lamp (except XBT GT2110): <ul style="list-style-type: none"> ● Green ON: the CF card is inserted and the cover is closed, or the CF card is being accessed. ● Green OFF: the CF card is not inserted or is not being accessed.
F	Ethernet interface (10Base-T/100Base-TX) (except XBT GT2110/2120): RJ-45 connector is used, and the LED turns ON or OFF to indicate the current status. <ul style="list-style-type: none"> ● Green ON: data transmission available. ● Green OFF: no connection or subsequent loss of communication. ● Yellow ON: data transmission is occurring. ● Yellow OFF: no data transmission.
G	Power input terminal block: connects the XBT GT power cable's input and ground wires to the XBT GT.
H	USB interface (USB1.1): connects a data transfer cable or peripherals or PLC USB terminal port to XBT GT.
I	Serial interface COM1: connects a RS-232C or RS-422-485 (serial) cable (from the host/PLC) to the XBT GT (COM1 port).
J	Serial interface COM2: connects a RS-485 (serial) cable (from the PLC) to the XBT GT (COM2 port).
K	RS-485 line polarization selector switch.
L	CF card cover: covers the CF card slot. This cover must be closed when accessing the CF card (except XBT GT2110)(See <i>Location of CF Card DIP Switches, page 104</i>).
M	CF card socket: permits insertion of the CF card.

XBT GT2430

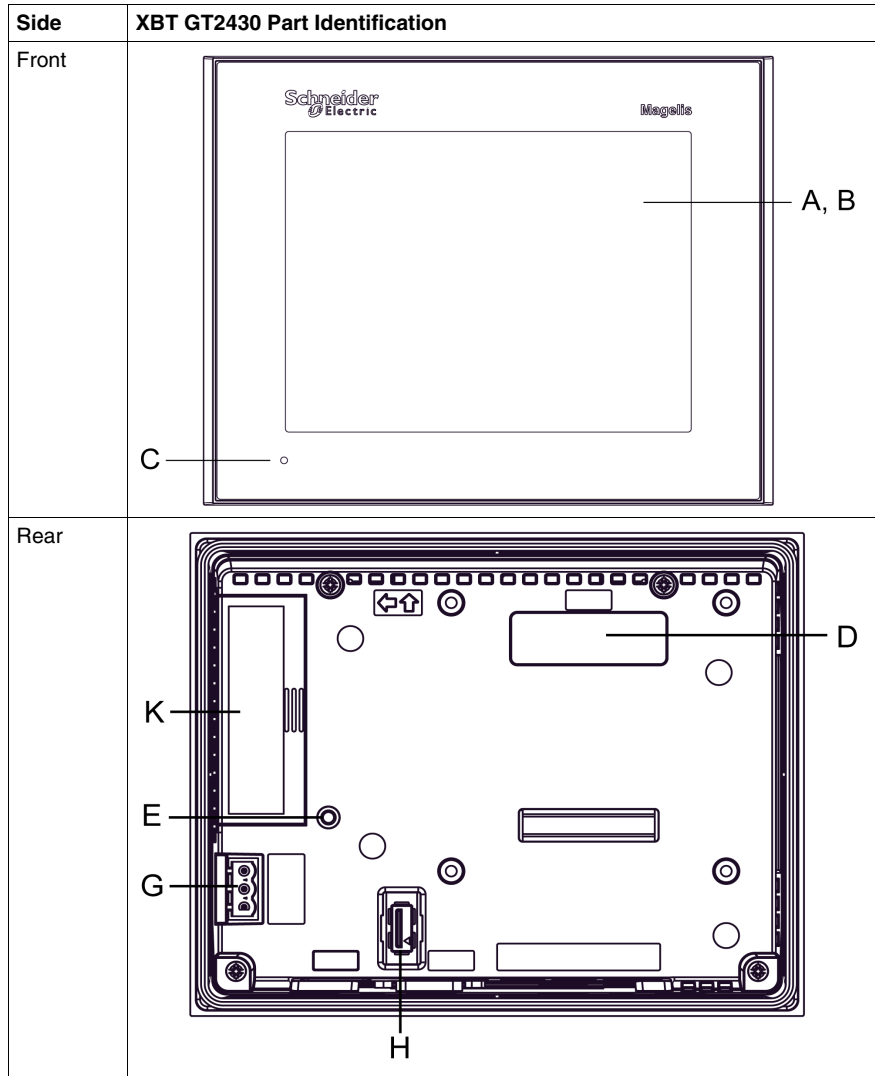

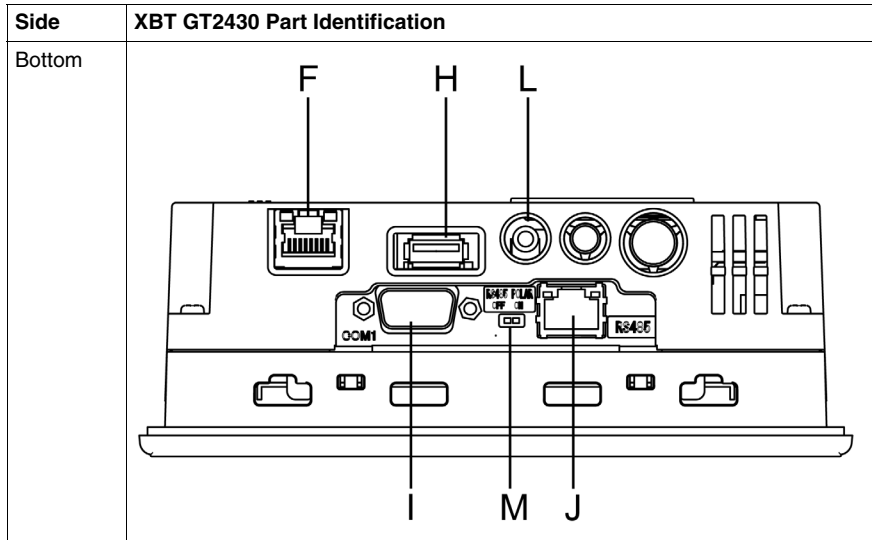

Part	Description
A	Display: displays user created screens and remote equipment variables.
B	Touch panel: performs screen change operations and sends data to the host (PLC).
C	Status LED: <ul style="list-style-type: none"> ● Green (steady): normal operation (power is ON) or OFFLINE operation. ● Orange (steady): backlight burnout is detected. ● Orange (blinking): during software startup. ● Red (steady): when power is turned ON. ● Not lit: power is OFF.
D	Expansion unit interface: connects expansion units with communication features.
E	CF card access lamp: <ul style="list-style-type: none"> ● Green ON: the CF card is inserted and the cover is closed, or the CF card is being accessed. ● Green OFF: the CF card is not inserted or is not being accessed.
F	Ethernet interface (10Base-T/100Base-TX): RJ-45 connector is used, and the LED turns ON or OFF to indicate the current status. <ul style="list-style-type: none"> ● Green ON: data transmission available. ● Green OFF: no connection or subsequent loss of communication. ● Yellow ON: data transmission is occurring. ● Yellow OFF: no data transmission.
G	Power input terminal block: connects the XBT GT power cable's input and ground wires to the XBT GT.
H	USB interface (USB1.1): connects a data transfer cable or peripherals or PLC USB terminal port to XBT GT.

Part	Description
I	Serial interface COM1: connects a RS-232C or RS-422-485 (serial) cable (from the host/PLC) to the XBT GT (COM1 port).
J	Serial interface COM2: connects a RS-485 (serial) cable (from the PLC) to the XBT GT (COM2 port).
K	CF card cover: covers the CF card slot. This cover must be closed when accessing the CF card (See <i>Location of CF Card DIP Switches</i> , page 104).
L	Sound Output Interface.
M	RS-485 line polarization selector switch.

XBT GT4000 Series

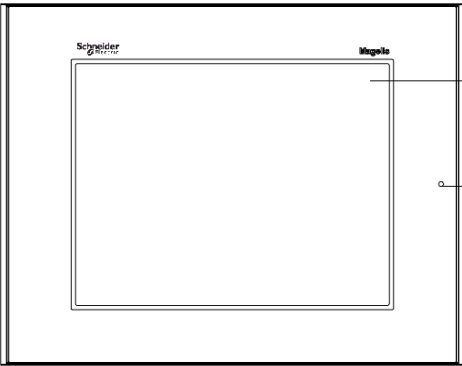
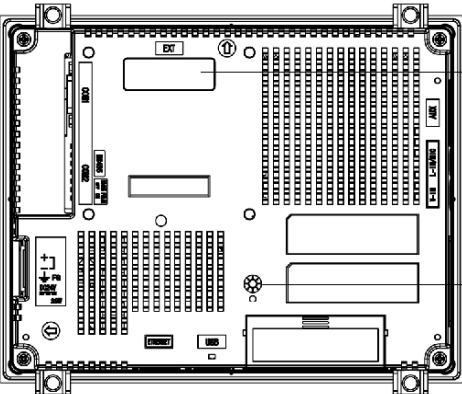
Side	XBT GT4000 series Part Identification
Front	
Rear	

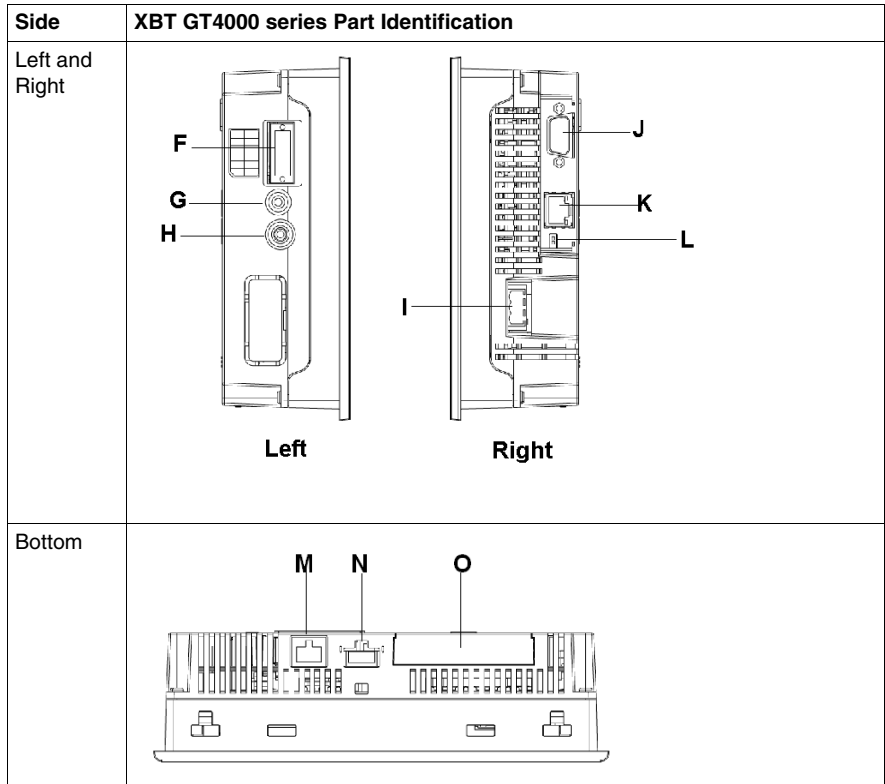

Part	Description
A	Display: displays user created screens and remote equipment variables.
B	Touch Panel: performs screen change operations and sends data to the host (PLC).
C	Status LED: <ul style="list-style-type: none"> ● Green (steady): normal operation (power is ON) or OFFLINE operation. ● Orange (steady): backlight burnout is detected. ● Orange (blinking): during software startup. ● Red (steady): when power is turned ON. ● Not lit: power is OFF.
D	Expansion unit interface: connects expansion units with communication features.
E	CF card access lamp: <ul style="list-style-type: none"> ● Green ON: the CF Card is inserted and the Cover is closed, or the CF Card is being accessed. ● Green OFF: the CF Card is not inserted or is not being accessed.

Part	Description
F	Auxiliary input/output/voice output interface (AUX). This interface is used for: <ul style="list-style-type: none"> ● External reset ● Alarm output ● Buzzer output ● Sound output
G	Audio input interface (L-IN/MIC): this interface is used to connect a microphone (use mini jack connector of 3.5 mm (0.13 in.)) (XBT GT4340 only).
H	Video input interface: this interface is used to connect a video camera NTSC (59.9 Hz)/PAL (50 Hz). Use with the RCA convertor 75 Ω (XBT GT4340 only).
I	Power plug connector: the power cable is connected through this connector.
J	Serial interface COM1: connects a RS-232C or RS-422-485 (serial) cable (from the host/PLC) to the XBT GT (COM1 port).
K	Serial interface COM2: connects a RS-485 (serial) cable (from the PLC) to the XBT GT (COM2 port).
L	RS-485 line polarization selector switch.
M	Ethernet interface (10Base-T/100Base-TX) (except XBT GT2110/2220): RJ-45 connector is used, and the LED turns ON or OFF to indicate the current status. <ul style="list-style-type: none"> ● Green ON: data transmission available. ● Green OFF: no connection or subsequent loss of communication. ● Yellow ON: data transmission is occurring. ● Yellow OFF: no data transmission.
N	USB host interface (USB1.1): connects a data transfer cable or peripherals or PLC USB terminal port to XBT GT.
O	CF card cover: covers the CF card slot. This cover must be closed when accessing to the CF card (See <i>Location of CF Card DIP Switches, page 104</i>).

XBT GT5230

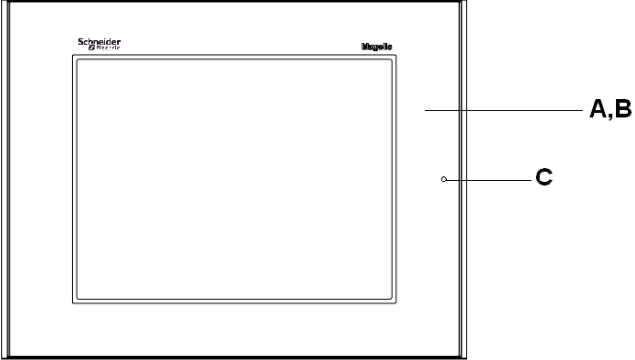
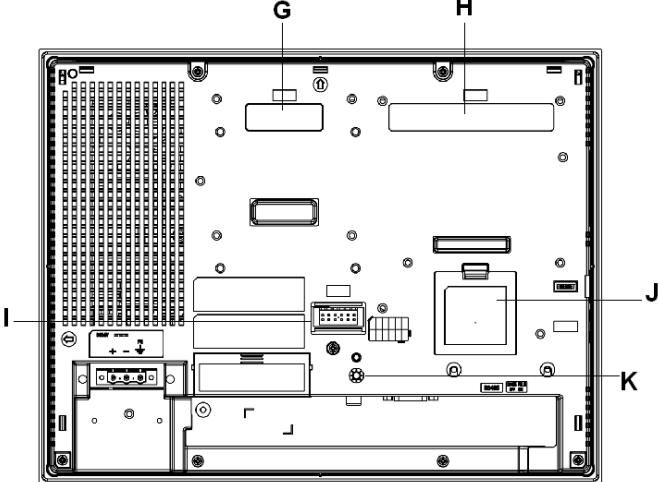
Side	XBT GT5230 Part Identification
Front	
Rear	

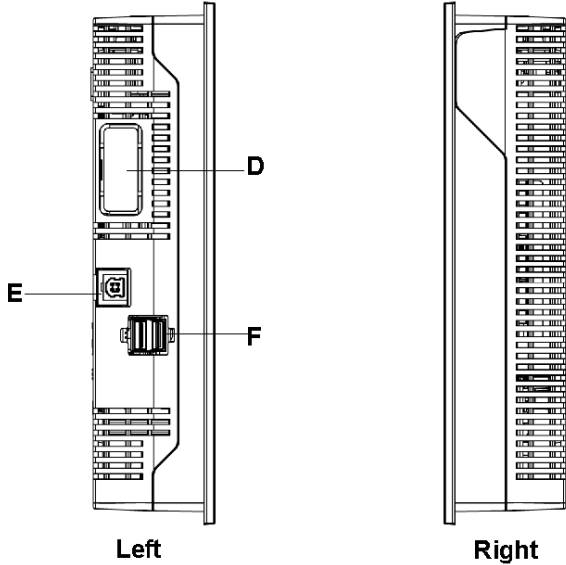
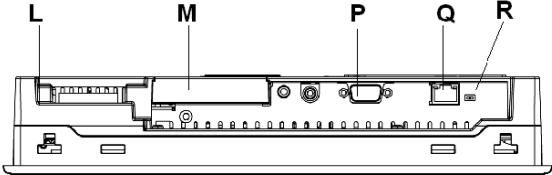
Side	XBT GT5230 Part Identification
Left and Right	 <p style="text-align: center;">Left Right</p>
CF Card Cover Open	 <p style="text-align: center;">L M P Q R</p>

XBT GT5330/5340/5430

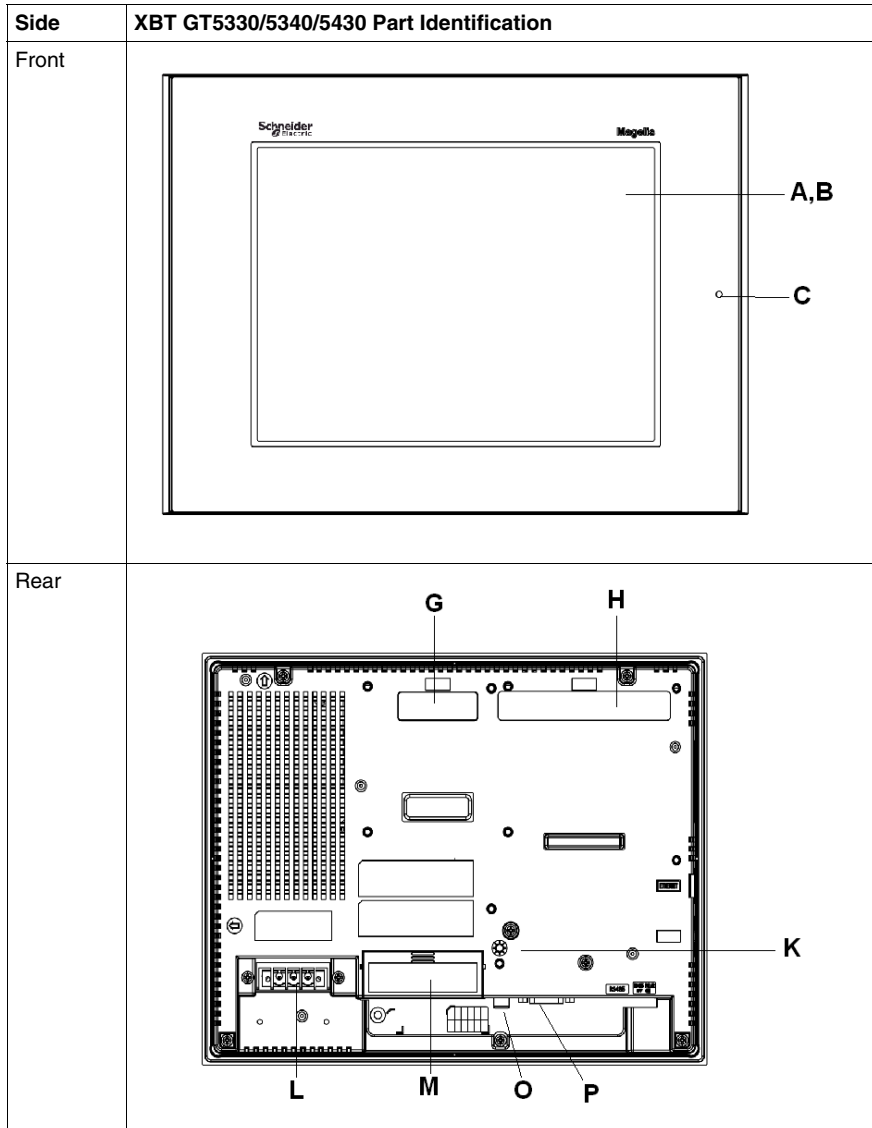

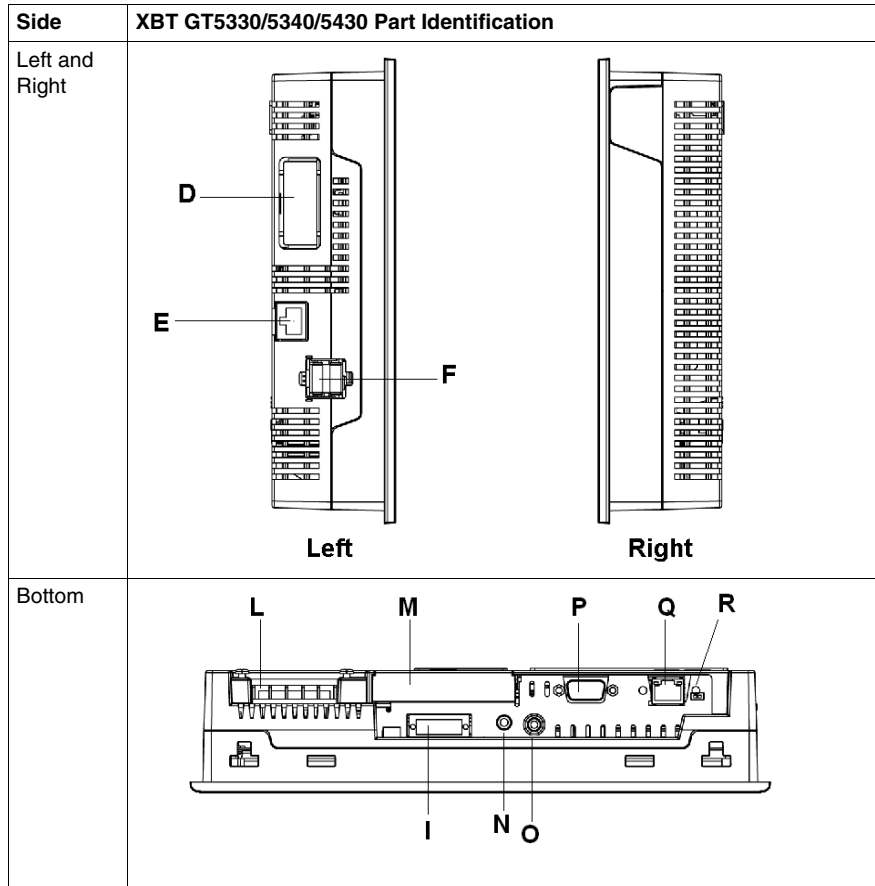

Part	Description
A	Display: displays user created screens and remote equipment variables.
B	Touch panel: performs screen change operations and sends data to the host PLC.
C	Status LED: <ul style="list-style-type: none"> ● Green (steady): normal operation (power is ON) or OFFLINE operation. ● Orange (steady): backlight burnout is detected. ● Orange (blinking): during software startup. ● Red (steady): when power is turned ON ● Not lit: power is OFF
D	Expansion unit interface: connects expansion units with communication features.

Part	Description
E	Ethernet interface (LAN) (10Base-T/100Base-TX): RJ-45 connector is used, and the LED turns ON or OFF to indicate the current status. <ul style="list-style-type: none"> ● Green ON: data transmission available. ● Green OFF: no connection or subsequent loss of communication. ● Yellow ON: data transmission is occurring. ● Yellow OFF: no data transmission.
F	USB host interface (USB1.1) (x2): connects a data transfer cable, USB-compatible printer, peripherals, or a PLC USB terminal port to the XBT GT. The maximum communication distance is 5 m (196.84 in.).
G	Expansion unit interface (EXT1): connects expansion units with communication features.
H	Expansion unit interface (EXT2): extends a display function
I	Auxiliary input/output/voice output interface (AUX). This interface is used for: <ul style="list-style-type: none"> ● External reset ● Alarm output ● Buzzer output ● Sound output
J	Expansion memory interface cover
K	CF card access lamp: <ul style="list-style-type: none"> ● Green ON: the CF card is inserted and the cover is closed, or the CF card is being accessed. ● Green OFF: the CF card is not inserted or is not being accessed.
L	Power plug connector: power cable is connected to this connector.
M	CF card cover : the CF card I/F and DIP Switches are located in the CF card cover (they are accessible when the card cover is open). This cover must be closed when accessing the CF card (See <i>Location of CF Card DIP Switches, page 104.</i>)
N	Audio input interface (L-IN/MIC): this interface is used to connect a microphone (use mini jack connector of 3.5 mm (0.13 in.)) (XBT GT5340 only).
O	Video input interface: this interface is used to connect a video camera NTSC (59.9 Hz)/PAL (50 Hz). Use with the RCA convertor 75 Ω (XBT GT5340 only).
P	Serial interface COM1: connects a RS-232C or RS-422-485 (serial) cable (from the host PLC) to the XBT GT (COM1 port).
Q	Serial interface COM2: connects a RS-485 (serial) cable (from the host PLC) to the XBT GT (COM2 port).
R	RS-485 line polarization selector switch

XBT GT6000 Series

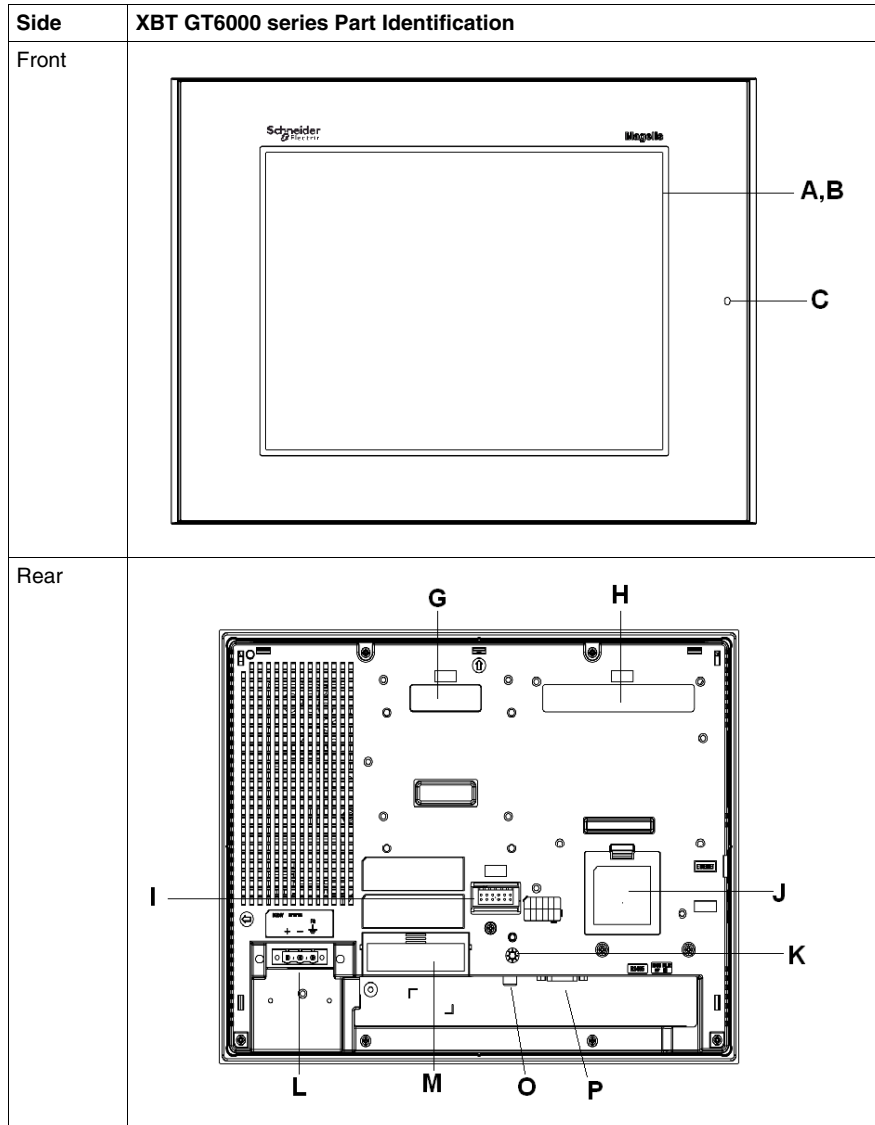

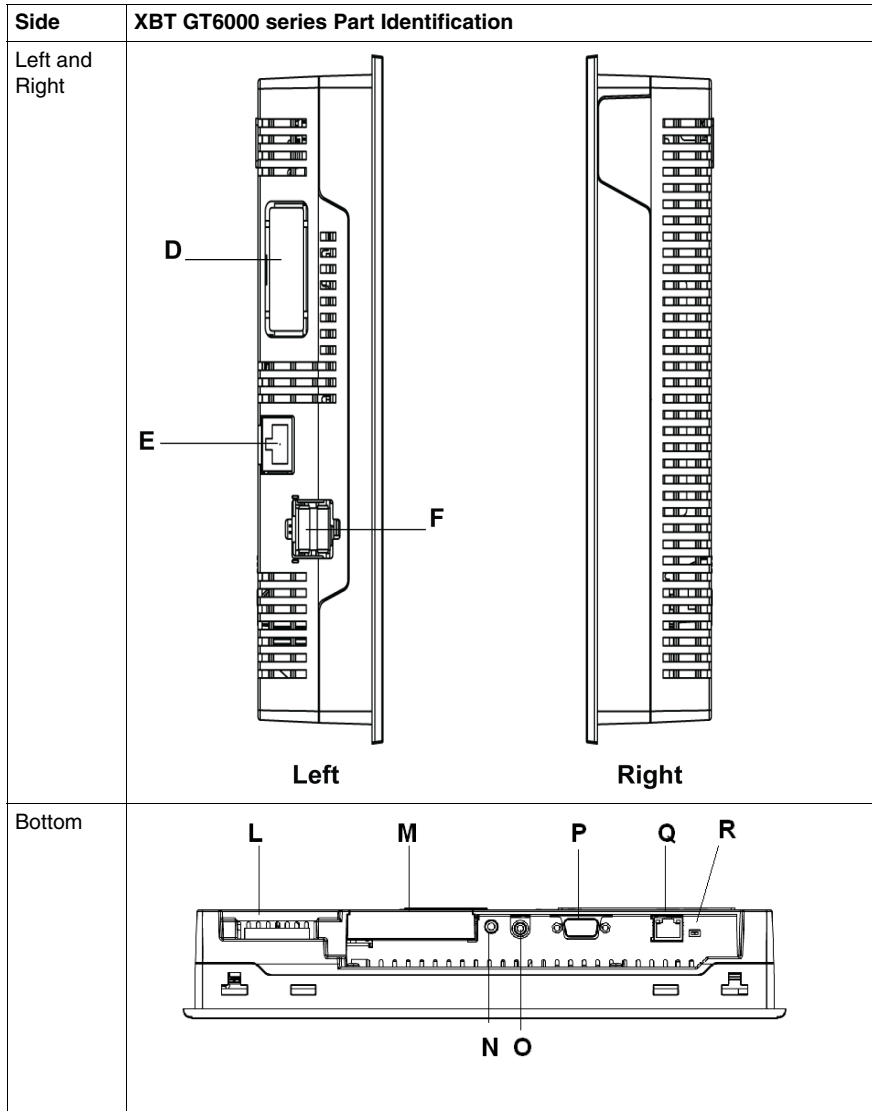

Part	Description
A	Display: displays user created screens and remote equipment variables.
B	Touch panel: performs screen change operations and sends data to the host PLC.

Part	Description
C	Status LED: <ul style="list-style-type: none"> ● Green (steady): normal operation (power is ON) or OFFLINE operation. ● Orange (steady): backlight burnout is detected. ● Orange (blinking): during software startup. ● Red (steady): when power is turned ON ● Not lit: power is OFF
D	Expansion unit interface: connects expansion units with communication features.
E	Ethernet interface (LAN) (10Base-T/100Base-TX): RJ-45 connector is used, and the LED turns ON or OFF to indicate the current status. <ul style="list-style-type: none"> ● Green ON: data transmission available. ● Green OFF: no connection or subsequent loss of communication. ● Yellow ON: data transmission is occurring. ● Yellow OFF: no data transmission.
F	USB host interface (USB1.1) (x2): connects a data transfer cable, USB-compatible printer, peripherals, or a PLC USB terminal port to the XBT GT. The maximum communication distance is 5 m (196.84 in.).
G	Expansion unit interface (EXT1): connects expansion units with communication features.
H	Expansion unit interface (EXT2): extends a display function
I	Auxiliary input/output/voice output interface (AUX). This interface is used for: <ul style="list-style-type: none"> ● External reset ● Alarm output ● Buzzer output ● Sound output
J	Expansion memory interface cover
K	CF card access lamp: <ul style="list-style-type: none"> ● Green ON: the CF card is inserted and the cover is closed, or the CF card is being accessed. ● Green OFF: the CF card is not inserted or is not being accessed.
L	Power plug connector: the power cable is connected through this connector.
M	CF card cover : the CF card I/F and DIP switches are located in the CF card cover (they are accessible when the card cover is open). This cover must be closed when accessing the CF card (See <i>Location of CF Card DIP Switches, page 104.</i>)
N	Audio input interface (L-IN/MIC): this interface is used to connect a microphone (use mini jack connector of 3.5 mm (0.13 in.)) (XBT GT6340 only).
O	Video input interface: this interface is used to connect a video camera NTSC (59.9 Hz)/PAL (50 Hz). Use with the RCA convertor 75 Ω (XBT GT6340 only).
P	Serial interface COM1: connects a RS-232C or RS-422-485 (serial) cable (from the host PLC) to the XBT GT (COM1 port).

Part	Description
Q	Serial interface COM2: connects a RS-485 (serial) cable (from the host PLC) to the XBT GT (COM2 port).
R	RS-485 line polarization selector switch

XBT GT7000 Series

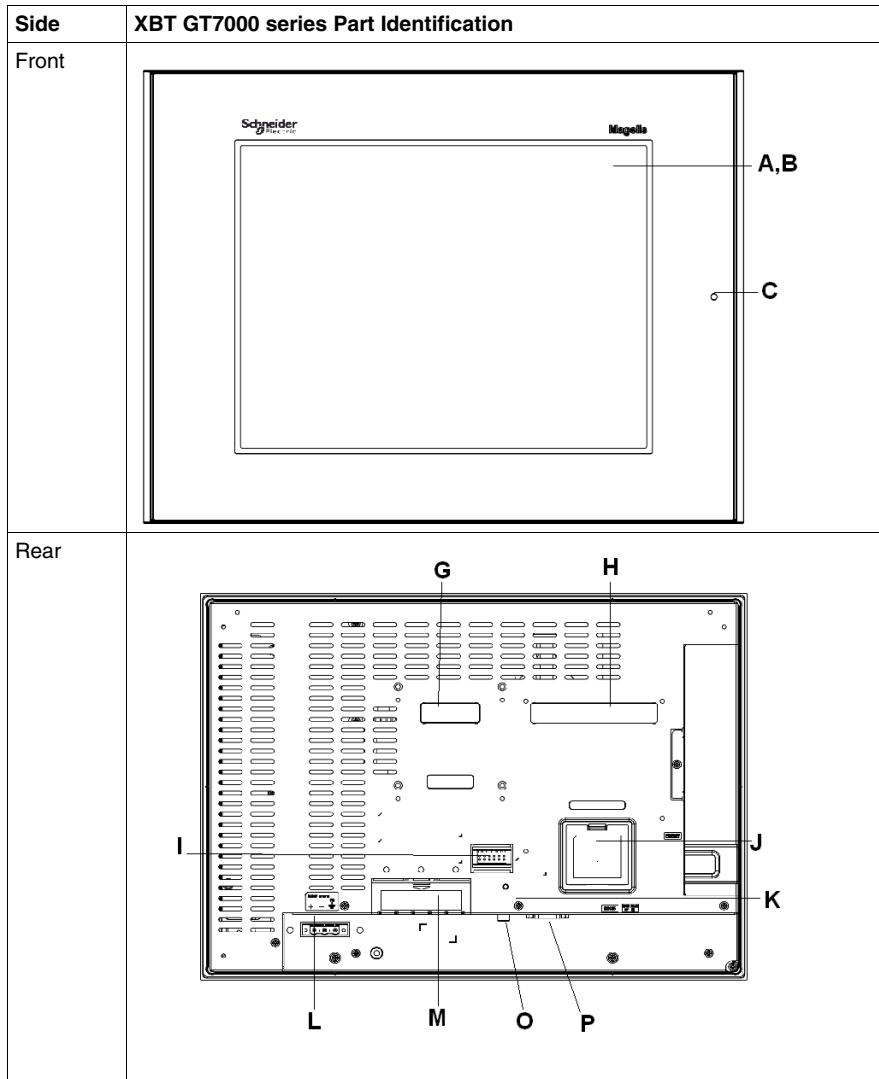

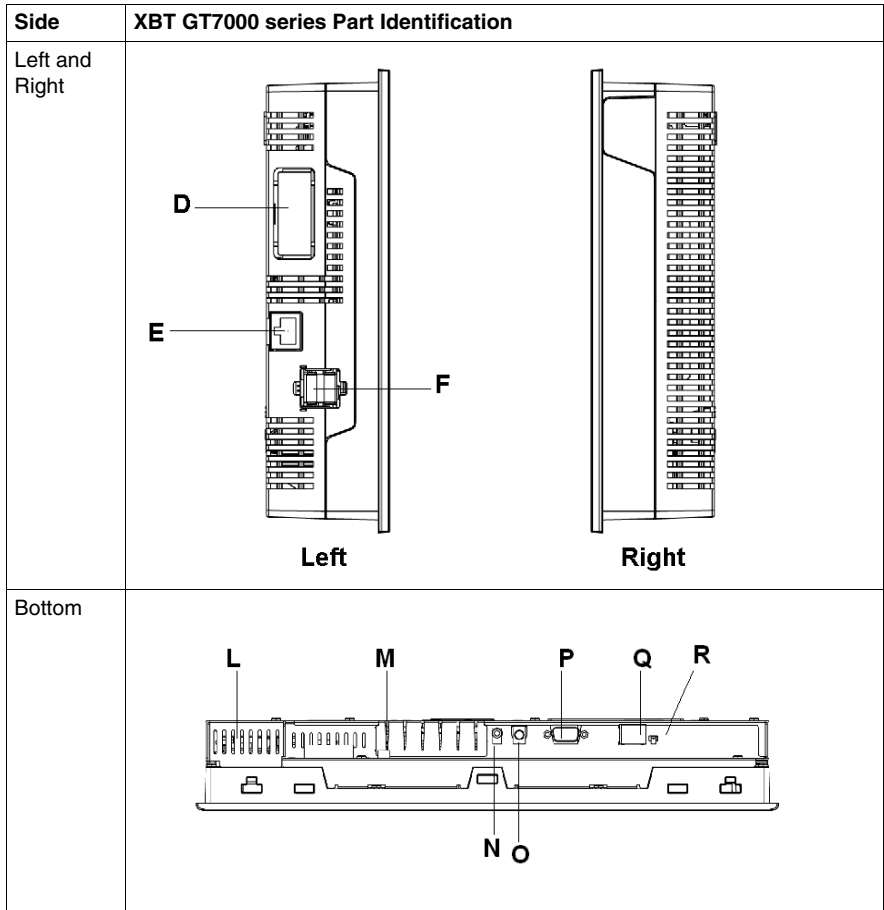

Part	Description
A	Display: displays user created screens and remote equipment variables.
B	Touch panel: performs screen change operations and sends data to the host PLC.
C	Status LED: <ul style="list-style-type: none"> ● Green (steady): normal operation (power is ON) or OFFLINE operation. ● Orange (steady): backlight burnout is detected. ● Orange (blinking): during software startup. ● Red (steady): when power is turned ON ● Not lit: power is OFF
D	Expansion unit interface: connects expansion units with communication features.

Part	Description
E	<p>Ethernet interface (LAN) (10Base-T/100Base-TX): RJ-45 connector is used, and the LED turns ON or OFF to indicate the current status.</p> <ul style="list-style-type: none"> ● Green ON: data transmission available. ● Green OFF: no connection or subsequent loss of communication. ● Yellow ON: data transmission is occurring. ● Yellow OFF: no data transmission.
F	<p>USB host interface (USB1.1) (x2): connects a data transfer cable, USB-compatible printer, peripherals, or a PLC USB terminal port to the XBT GT. The maximum communication distance is 5 m (196.84 in.).</p>
G	<p>Expansion unit interface (EXT1): connects expansion units with communication features.</p>
H	<p>Expansion unit interface (EXT1): extends a display function</p>
I	<p>Auxiliary input/output/voice output interface (AUX) This interface is used for:</p> <ul style="list-style-type: none"> ● External reset ● Alarm output ● Buzzer output ● Sound output
J	<p>Expansion memory interface cover</p>
K	<p>CF card access lamp:</p> <ul style="list-style-type: none"> ● Green ON: the CF card is inserted and the cover is closed, or the CF card is being accessed. ● Green OFF: the CF card is not inserted or is not being accessed.
L	<p>Power plug connector: power cable is connected to this connector.</p>
M	<p>CF card cover : the CF card I/F and DIP switches are located in the CF card cover (they are accessible when the card cover is open). This cover must be closed when accessing the CF card (See <i>Location of CF Card DIP Switches, page 104.</i>)</p>
N	<p>Audio input interface (L-IN/MIC): this interface is used to connect a microphone (use mini jack connector of 3.5 mm (0.13 in.)) (XBT GT7340 only).</p>
O	<p>Video input interface: this interface is used to connect a video camera NTSC (59.9 Hz)/PAL (50 Hz). Use with the RCA convertor 75 Ω (XBT GT7340 only).</p>
P	<p>Serial interface COM1: connects a RS-232C or RS-422-485 (serial) cable (from the host PLC) to the XBT GT (COM1 port).</p>
Q	<p>Serial interface COM2: connects a RS-485 (serial) cable (from the host PLC) to the XBT GT (COM2 port).</p>
R	<p>RS-485 line polarization selector switch.</p>

XBT GK2000 Series

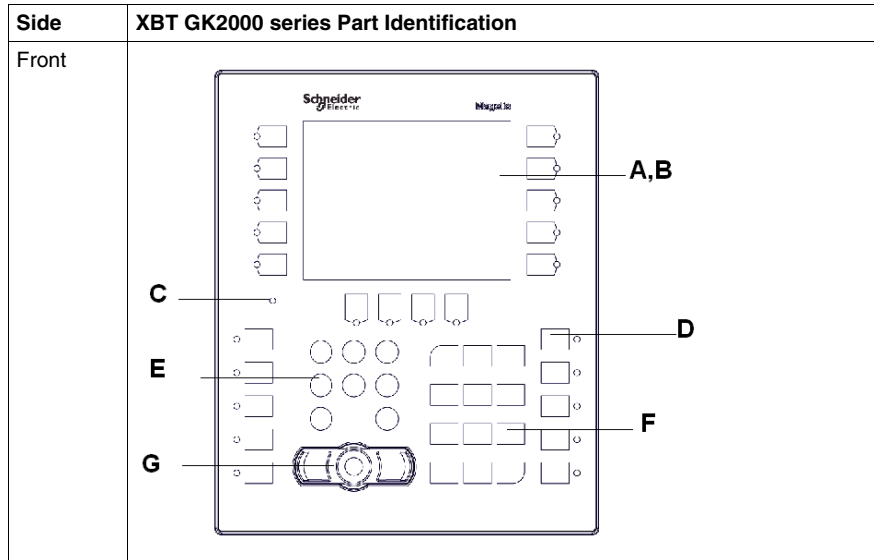

Part	Description
A	Display: displays user created screens and remote equipment variables.
B	Touch panel: performs screen change operations and sends data to the host PLC
C	Status LED: <ul style="list-style-type: none"> ● Green (steady): normal operation (power is ON) or OFFLINE operation. ● Orange (steady): backlight burnout is detected. ● Orange (blinking): during software startup. ● Not lit: power is OFF
D	Function keys (R1 to R10, R21 to R24, F1 to F10): used for function keys.
E	System keypad: controls various system operations.
F	Alphanumeric keypad: enables the user to input characters or numeric values.
G	Mouse pointer: the pointer moves the cursor and the buttons activate objects and enable data inputs.

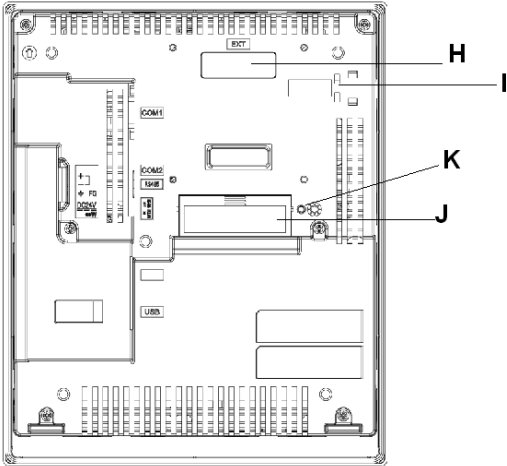
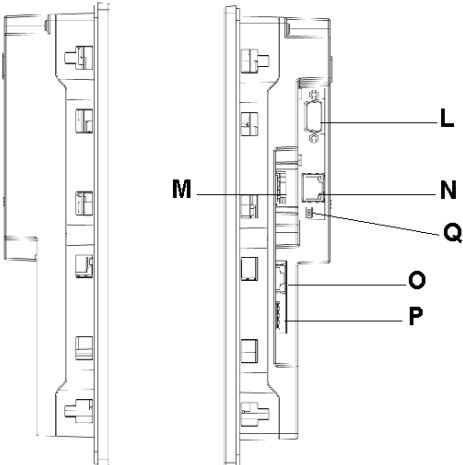
Side	XBT GK2000 series Part Identification
Rear	 <p>A top-down view of the rear panel of the XBT GK2000 series device. The panel features a central slot for a module, flanked by two smaller slots. Below the central slot is a USB port. The top edge has a series of pins labeled 'EXT'. The bottom edge has a series of pins labeled 'COM1', 'COM2', and 'USB'. Labels H, I, J, and K point to various components on the right side of the device.</p>
Left and Right	 <p>Two side views of the XBT GK2000 series device. The left view shows the profile of the device with a series of ports along the bottom edge. The right view shows the profile of the device with a series of ports along the top edge. Labels L, M, N, O, P, and Q point to various components on the right side of the device.</p>

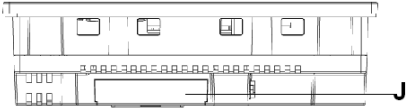
Side	XBT GK2000 series Part Identification
Bottom	

Part	Description
H	Expansion unit interface (EXT1): connects expansion units with communication features.
I	Ethernet indicator (except XBT GK2120): the LED turns ON or OFF to indicate the current status. <ul style="list-style-type: none"> ● Green ON: Data transmission available. ● Green OFF: No connection or subsequent loss of communication. ● Yellow ON: Data transmission is occurring. ● Yellow OFF: No data transmission.
J	CF card cover : the CF card socket and DIP Switches are located under the CF card cover (they are accessible when the card cover is open). This cover must be closed when accessing the CF card (See <i>Location of CF Card DIP Switches, page 104.</i>)
K	CF card access lamp: <ul style="list-style-type: none"> ● Green ON: the CF card is inserted and the cover is closed, or the CF card is being accessed. ● Green OFF: the CF card is not inserted or is not being accessed.
L	Serial interface COM1: connects a RS-232C or RS-422-485 (Serial) cable (from the host PLC) to the unit (COM1 port).
M	Power input terminal block: connects the units power cable's input and ground wires to the unit.
N	Serial interface COM2: connects a RS-485 (serial) cable (from the host PLC) to the unit (RS-485 port).
O	Ethernet interface (10Base-T/100Base-TX) (except XBT GK2120): RJ-45 connector is used.
P	USB host interfaces (USB1.1) : connects a data transfer cable, USB-compatible printer, peripherals, or a PLC USB terminal port to the XBT GK. The maximum communication distance is 5 m (196.84 in.).
Q	RS-485 line polarization selector switch.

XBT GK5330

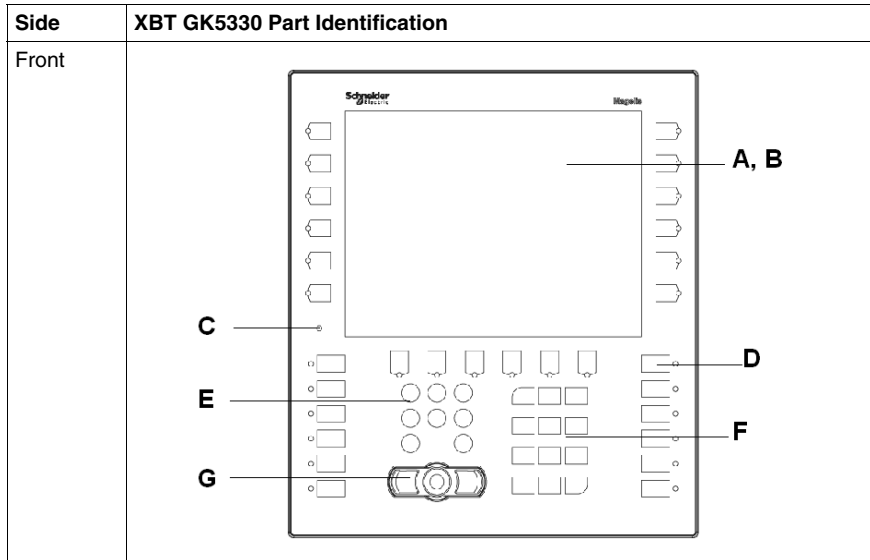

Part	Description
A	Display: displays user created screens and remote equipment variables.
B	Touch panel: performs screen change operations and sends data to the host PLC
C	Status LED: <ul style="list-style-type: none"> ● Green (steady): normal operation (power is ON) or OFFLINE operation. ● Orange (steady): backlight burnout is detected. ● Orange (blinking): during software startup. ● Not lit: power is OFF
D	Function keys (R1 to R12, R21 to R26, F1 to F12): used for function keys.
E	System keypad: controls various system operations.
F	Alphanumeric keypad: enables the user to input characters or numeric values.
G	Mouse pointer: the pointer moves the cursor and the buttons activate objects and enable data inputs.

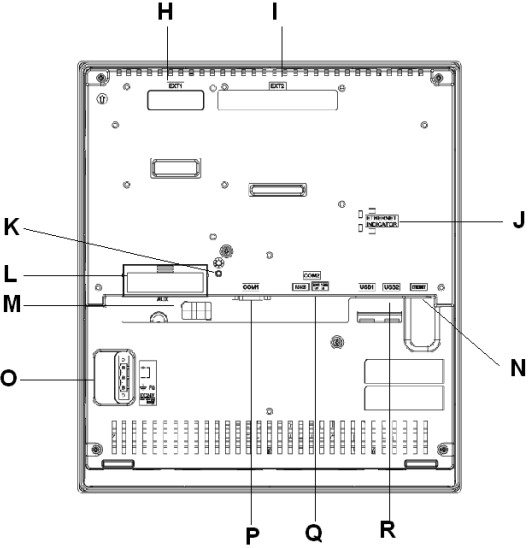
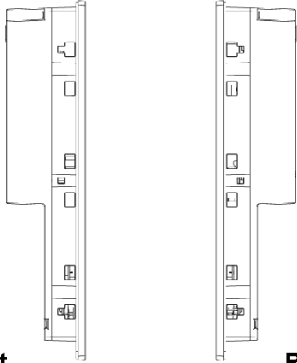
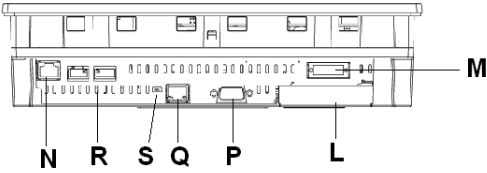
Side	XBT GK5330 Part Identification
Rear	 <p>Diagram showing the rear view of the XBT GK5330 device with callout letters H through R identifying various components:</p> <ul style="list-style-type: none"> H: Top edge connector I: Top edge connector J: Micro-USB port K: Internal component L: Internal component M: Internal component N: Internal component O: Internal component P: Bottom edge connector Q: Bottom edge connector R: Bottom edge connector
Left and Right	 <p>Diagram showing the left and right side views of the XBT GK5330 device:</p> <ul style="list-style-type: none"> Left Right
Bottom	 <p>Diagram showing the bottom view of the XBT GK5330 device with callout letters L through S identifying various components:</p> <ul style="list-style-type: none"> L: Bottom edge connector M: Bottom edge connector N: Bottom edge connector R: Bottom edge connector S: Bottom edge connector Q: Bottom edge connector P: Bottom edge connector

Part	Description
H	Expansion unit interface (EXT1): connects expansion units with communication features.
I	Expansion unit interface (EXT2): connects expansion units with communication features.
J	Ethernet indicator: the LED turns ON or OFF to indicate the current status. <ul style="list-style-type: none"> ● Green ON: data transmission available. ● Green OFF: no connection or subsequent loss of communication. ● Yellow ON: data transmission is occurring. ● Yellow OFF: no data transmission.
K	CF card access lamp: <ul style="list-style-type: none"> ● Green ON: the CF card is inserted and the cover is closed, or the CF card is being accessed. ● Green OFF: the CF card is not inserted or is not being accessed.
L	CF card cover : The CF card socket and DIP switches are located in the CF card cover (they are accessible when the card cover is open). This cover must be closed when accessing the CF card (See <i>Location of CF Card DIP Switches, page 104.</i>)
M	Auxiliary input/output/voice output interface (AUX) This interface is used for: <ul style="list-style-type: none"> ● External reset ● Alarm output ● Buzzer output ● Sound output
N	Ethernet interface (10Base-T/100Base-TX): RJ-45 connector is used.
O	Power input terminal block: connects the XBT GK power cable's input and ground wires to the unit.
P	Serial interface COM1: connects a RS-232C or RS-422 (serial) cable (from the host PLC) to the unit (COM1 port).
Q	Serial interface COM2: connects a RS-485 (serial) cable (from the host PLC) to the unit (RS-485 port).
R	USB host interfaces (USB1.1) (x2): connects a data transfer cable, USB-compatible printer, peripherals, or a PLC USB terminal port to the XBT GK. The maximum communication distance is 5 m (196.84 in.).
S	RS-485 line polarization selector switch.

XBT GH2460

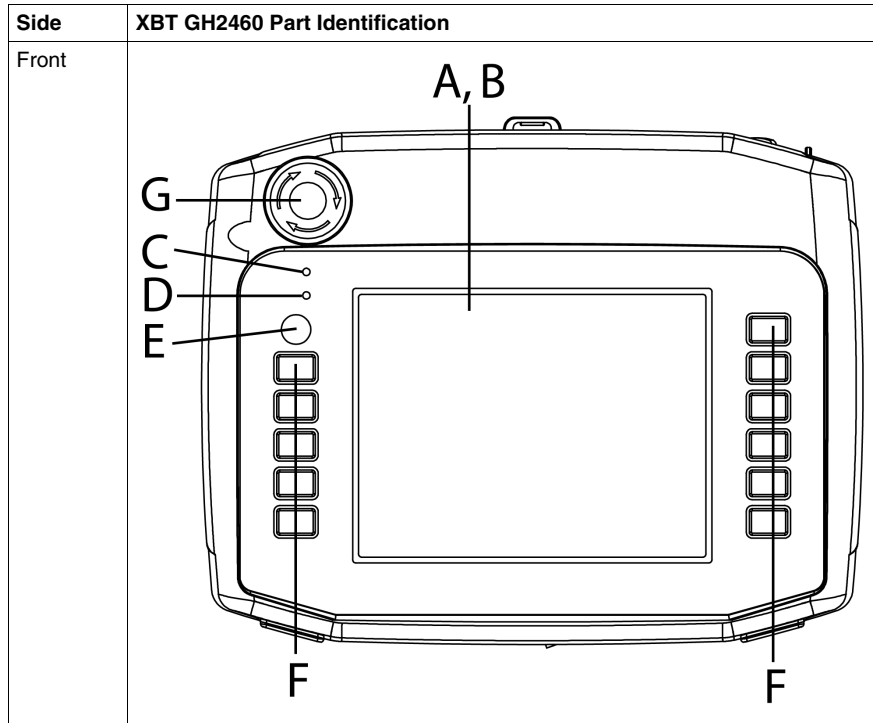

Part	Description
A	Display: displays user created screens and remote equipment variables.
B	Touch panel: performs screen change operations and sends data to the host PLC
C	Status LED: <ul style="list-style-type: none"> ● Green ON: normal operation (power is ON) or OFFLINE operation. ● Orange ON: backlight burnout is detected. ● Orange (blinking): during software startup. ● Not lit: power is OFF.
D	Operation LED: <ul style="list-style-type: none"> ● Green ON: the Operation switch is ON. ● Not lit: the Operation switch is OFF.
E	Operation Switch: When this switch is pressed, the XBT GH unit can accept input from the touch screen and function switches.
F	Function Switches: Functions are set up with the screen design software. For details see the Vijeo-Designer online help.
G	Emergency Switch

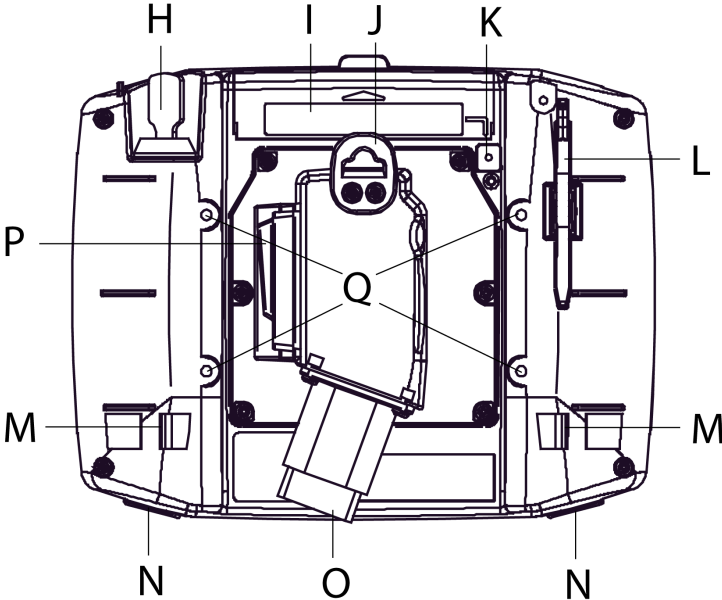
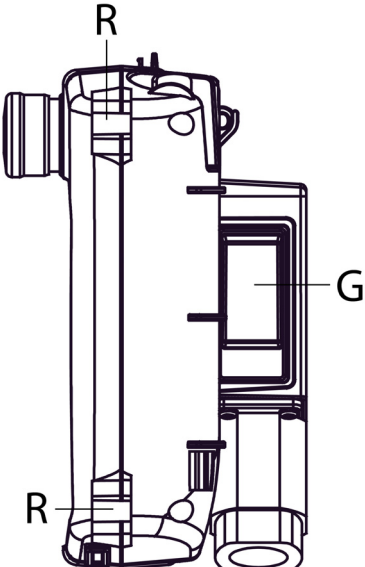
Side	XBT GH2460 Part Identification
Rear	 <p>A technical line drawing showing the rear view of the XBT GH2460 instrument housing. The drawing is annotated with callout letters: H (top left corner), I (top center), J (top right), K (top right corner), L (right side), M (bottom left and bottom right corners), N (bottom left and bottom right corners), O (bottom center), P (left side), and Q (center). The instrument is shown with its top cover removed, revealing internal components like the sensor and wiring.</p>
Right	 <p>A technical line drawing showing the right side view of the XBT GH2460 instrument housing. The drawing is annotated with callout letters: R (top and bottom) and G (middle). The drawing shows the vertical profile of the instrument, including the sensor assembly at the top and the base.</p>

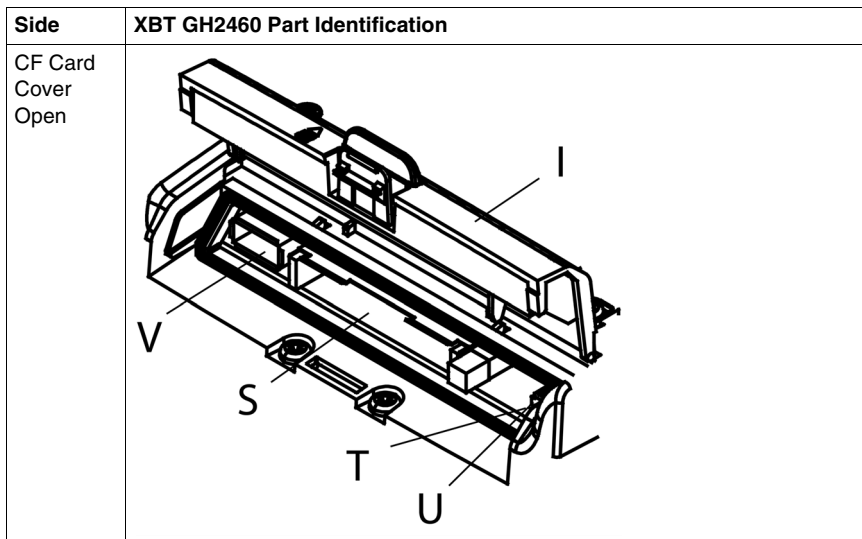

Part	Description
H	Key Switch: Turning the key turns ON/OFF the XBT GH unit power supply.
I	CF card cover: The CF card socket and DIP switches are located in the CF card cover (they are accessible when the card cover is open). This cover must be closed when accessing the CF card (See <i>Location of CF Card DIP Switches</i> , page 104.)
J	Hook: A hook for temporarily hanging the XBT GH unit on a wall. Note: The following is recommended to be used as pairs for this hook: <ul style="list-style-type: none"> ● A $\varnothing 7$ or less, rod-shaped or S-shaped hook. ● M4 pan-head machine screw, which head diameter is $\varnothing 7$ or less. ● Panel thickness: 1...1.6mm (0.04...0.06 in.) ● Panel width: 14mm (0.55 in.)
K	CF card access lamp: <ul style="list-style-type: none"> ● Green ON: the CF card is inserted and the cover is closed, or the CF card is being accessed. ● Green OFF: the CF card is not inserted or is not being accessed.
L	Stylus: Use the stylus for entering data to the touch screen interface.
M	Hand Strap Attachment Slots (2)
N	Insertion hole (with cover) for Function Switch Sheet (2)
O	XBT GH Cable Connector (with Connector Cover)
P	3-Position Enable Switch: The switch provides three positions: <ul style="list-style-type: none"> ● The switch is not pressed (released). ● The switch is pressed to the intermediate position. ● The switch is pressed to the innermost position (fully pressed).

Part	Description
Q	Wall Adapter Attachment Slots: To mount the XBT GH unit to a panel or commercially available arm, attach the dedicated wall-hanging adapter (optional) to this slot.
R	Neck Strap Attachment Slots (4)
S	CF card interface: Insert the CF card in this slot.
T	LAN status LED: The LED turns ON or OFF to indicate the current status of the Ethernet transmission interface (10BASE-T/100BASE-TX). <ul style="list-style-type: none"> ● Green ON: Data transmission available. ● Green Flashing: Data transmission is occurring. ● Green OFF: No connection or subsequent loss of communication. ● Orange ON: Connecting with 100BASE-TX. ● Orange OFF: Connecting with 100BASE-TX or No connection.
U	Dip Switches: After inserting a CF Card, be sure to turn ON DIP Switch 4, and close the CF Card cover before using the GP unit. For more information, see “CF Card DIP Switches” on page 13.
V	USB Host Interface: Complies with USB 1.1. Uses a “TYPE-A” connector. Power supply voltage: DC5 V±5%, Output current: 500 mA (max). Connect to the transfer cable, storage device (USB memory, CF Card reader), etc. Maximum communication distance: 5 m (196.84 in.)

Terminal Configuration Switches

Introduction

The RS-485 line polarization selector switch is available on all XBT GT and XBT GK series.

The CF card DIP switches are available on:

- XBT GT2000 series
- XBT GT4000 series
- XBT GT5000 series
- XBT GT6000 series
- XBT GT7000 series
- XBT GK series
- XBT GH series

Parameters of RS-485 Line Polarization Selector Switch

The following table explains the RS-485 line polarization selector switch parameters:

Function	ON	OFF	Comment
Controls the polarization of the RS-485 serial line.	RS-485 serial line is polarized (620 Ω pull-up on D1 and 620 Ω pull-down on D0).	No internal polarization.	Polarization requires activation (ON) when the following two conditions are met: <ul style="list-style-type: none">• Modbus or Unitelway protocol is implemented• No other equipment is polarizing the bus

Location of CF Card DIP Switches

On XBT GH, XBT GK, and XBT GT2000 and higher units (except XBT GT2110), the CF card DIP switches are located under the CF card cover.

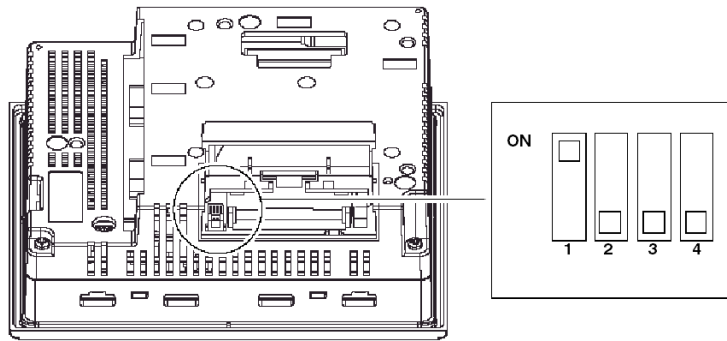

Parameter of CF Card DIP Switches

The following table explains CF card DIP switches parameters for the targets.

XBT GT2000 and higher and XBT GK			
Dip Switch	Function	ON	OFF
1	Controls downloading from CF card.	The application downloads from the CF Card and transfers into the internal memory.	-
2	Reserved	-	-
3	Reserved	-	-
4	Controls the forced closing of the CF card cover (used when CF card cover is damaged).	Forced close enabled.	Forced close disabled.

XBT GH			
Dip Switch	Function	ON	OFF
1	Controls downloading from CF card.	The application downloads from the CF Card and transfers into the internal memory.	-
2	Forced Transfer mode	Forced Transfer mode: ON	Forced Transfer mode: OFF
3	Reserved	-	-
4	Controls the forced closing of the CF card cover (used when CF card cover is damaged).	Forced close enabled.	Forced close disabled.

The following diagram describes in detail the way the unit behaves in BOOT mode, based on the DIP switch settings and the CF card status:

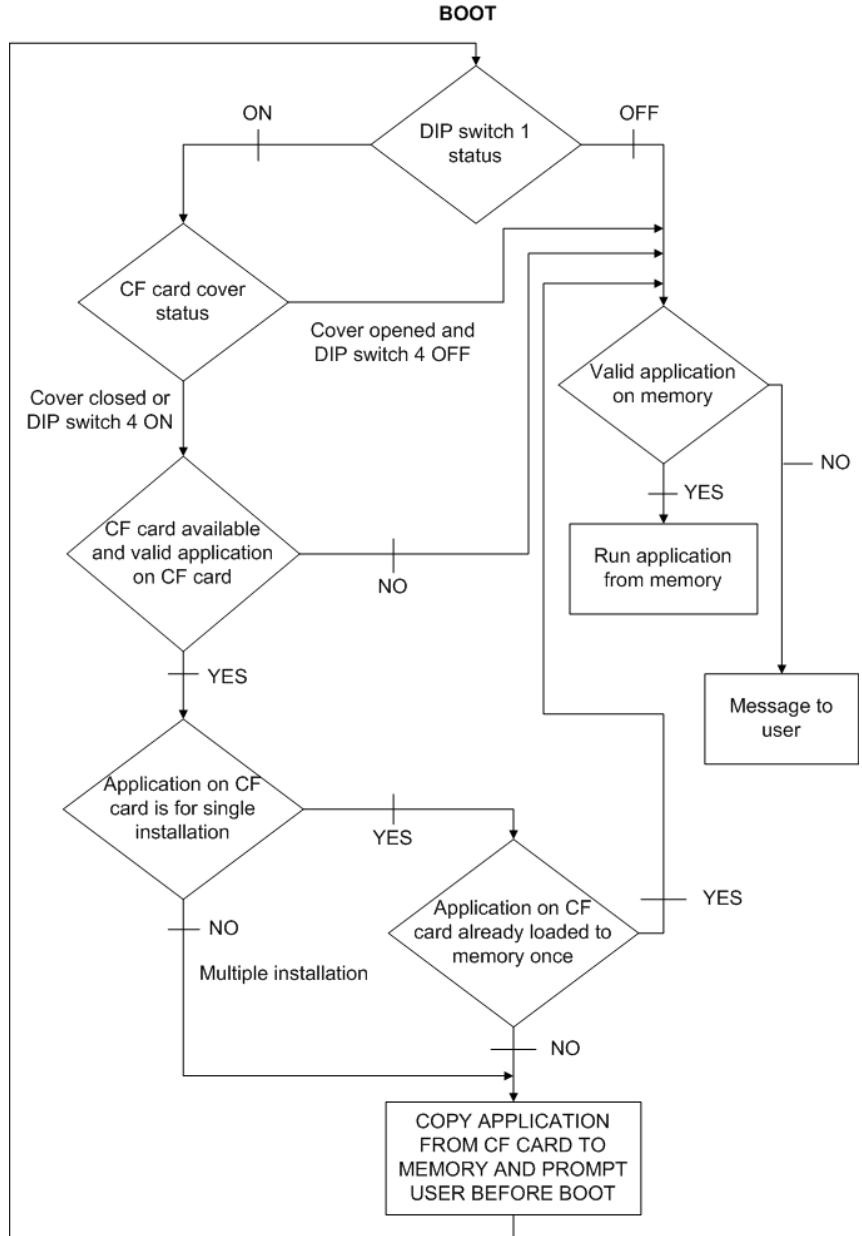

The following diagram describes in detail the way the unit behaves in RUN mode, based on the DIP switch settings and the CF card status:

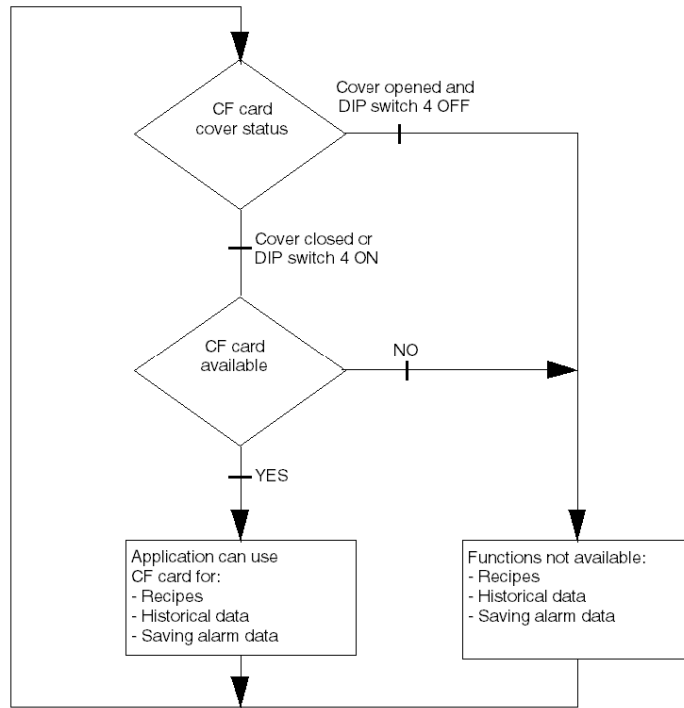

3.5 Dimensions

Overview

This section presents all the dimensions of XBT GT, XBT GK, and XBT GH units.

What Is in This Section?

This section contains the following topics:

Topic	Page
XBT GT1000 Series Dimensions	109
XBT GT1005 Series Dimensions	111
XBT GT2000 Series Dimensions	114
XBT GT4000 Series Dimensions	121
XBT GT5000 Series Dimensions	125
XBT GT6000 Series Dimensions	133
XBT GT7000 Series Dimensions	137
XBT GK2000 Series Dimensions	141
XBT GK5330 Dimensions	145
XBT GH2000 Series Dimensions	149
Panel Cut-out Dimension	151
Installation Fasteners	153

XBT GT1000 Series Dimensions

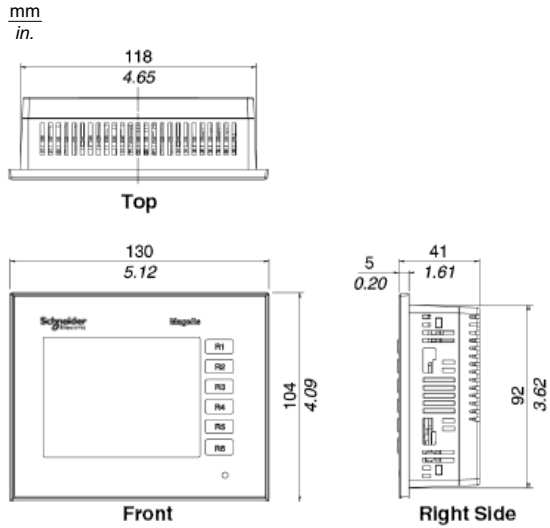

Installation with Spring Clips

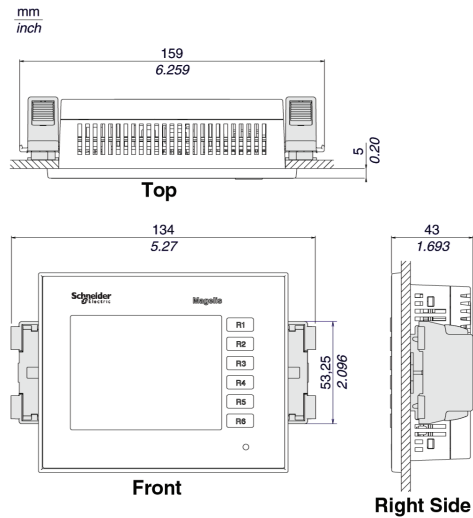

NOTE: XBT Z3002 spring clip fasteners must be ordered separately.

Installation with Screw Fasteners

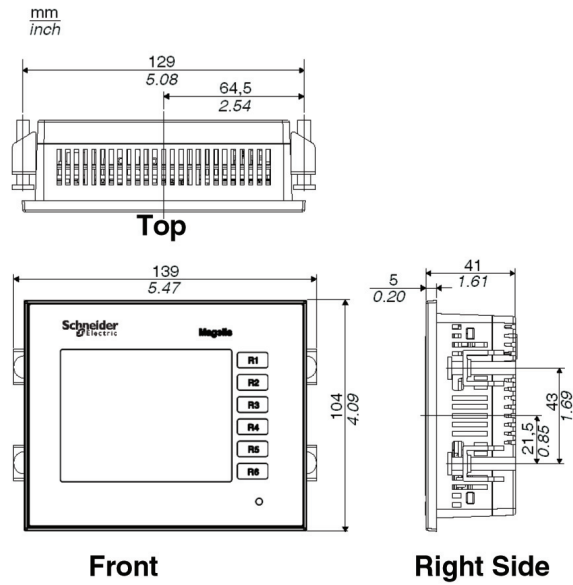

XBT GT1005 Series Dimensions

The following illustrations show the dimensions for the XBT GT1105, 1135, and 1335 panels.

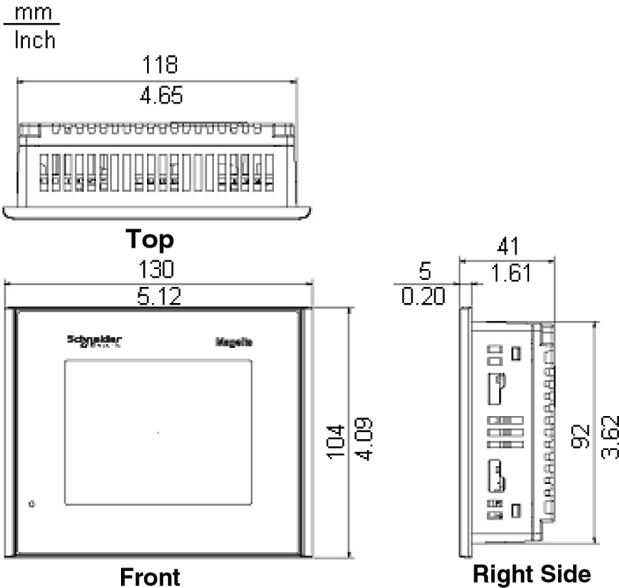

Dimensions with Cables

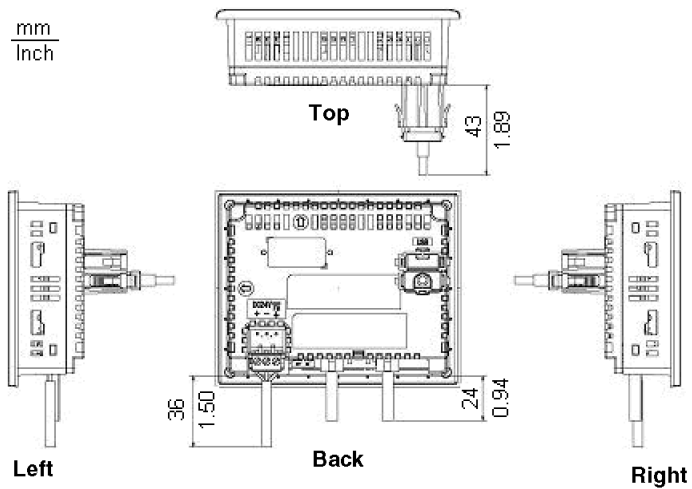

Installation with Spring Clips

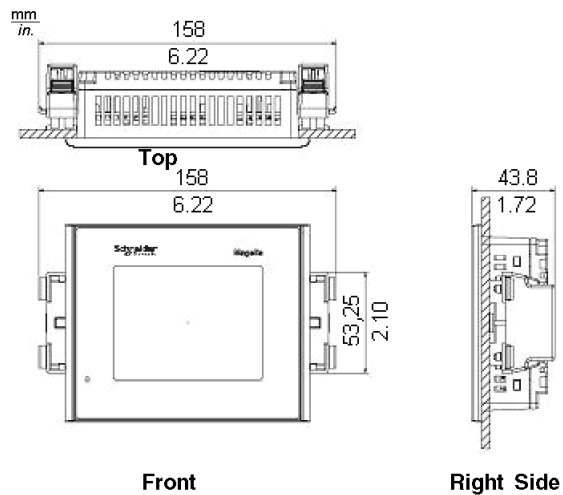

NOTE: XBT Z3002 spring clip fasteners must be ordered separately.

Installation with Screw Fasteners

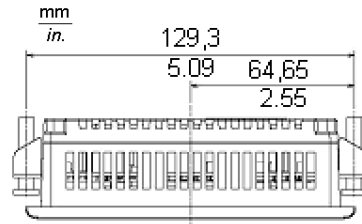

Top

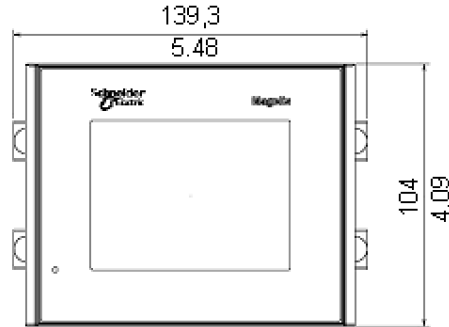

Front

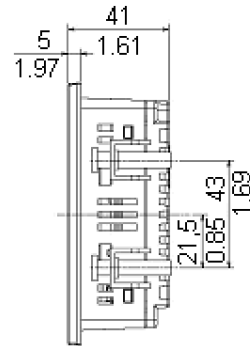

Right Side

XBT GT2000 Series Dimensions

The following four illustrations show the dimensions for the XBT GT2110, 2120, 2130, 2220, 2330, and 2930 panels.

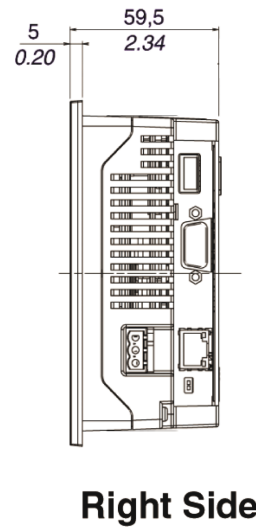
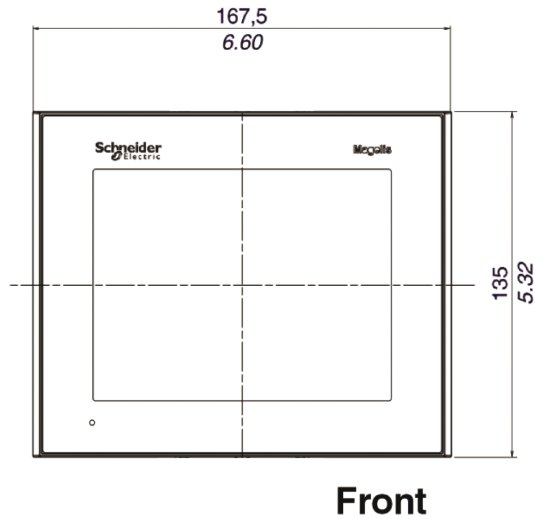
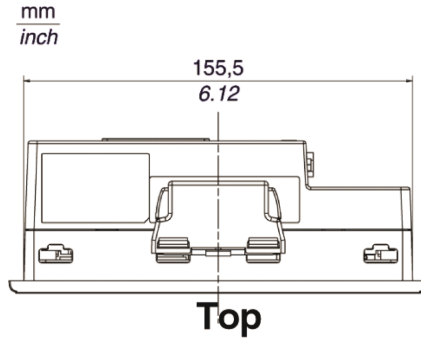

Dimensions with Cables

$\frac{\text{mm}}{\text{inch}}$

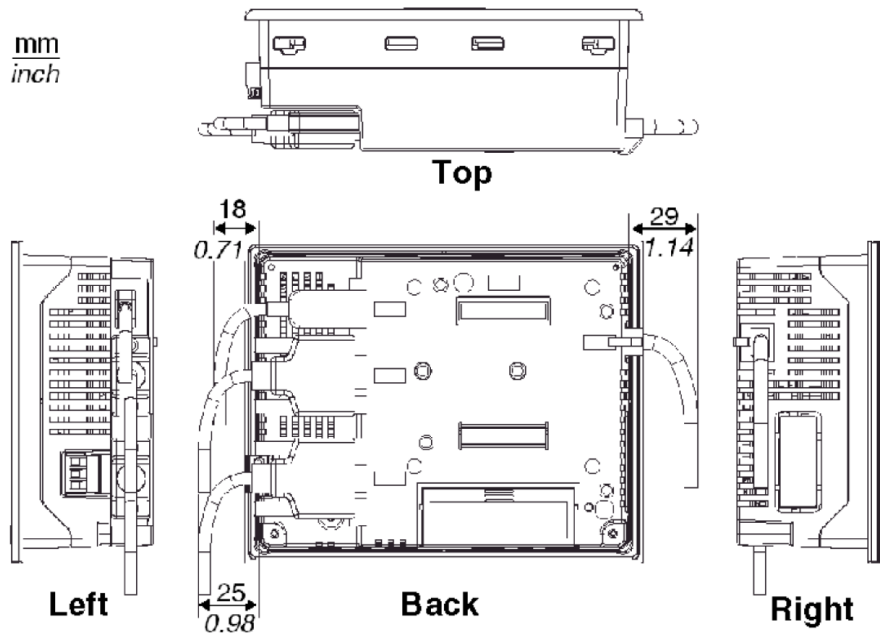

Installation with Spring Clips

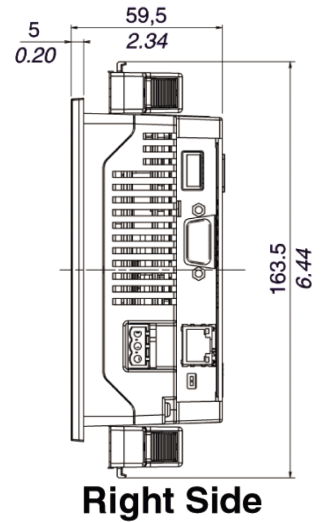
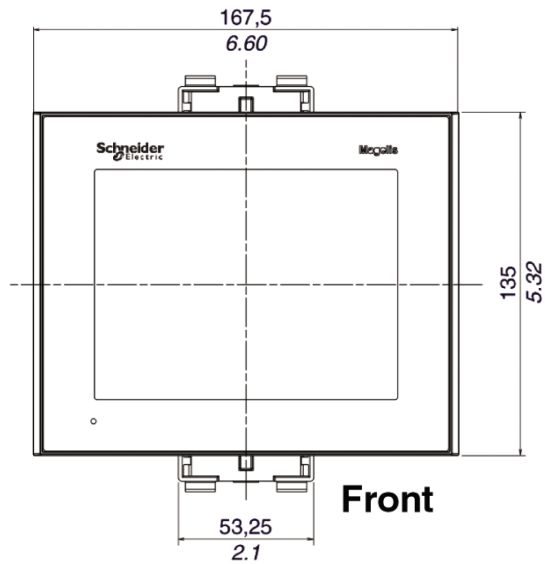
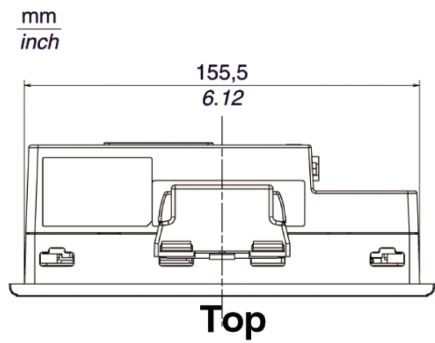

NOTE: Spring clip fasteners must be ordered separately (ref. XBT Z3002)

Installation with Screw Fasteners

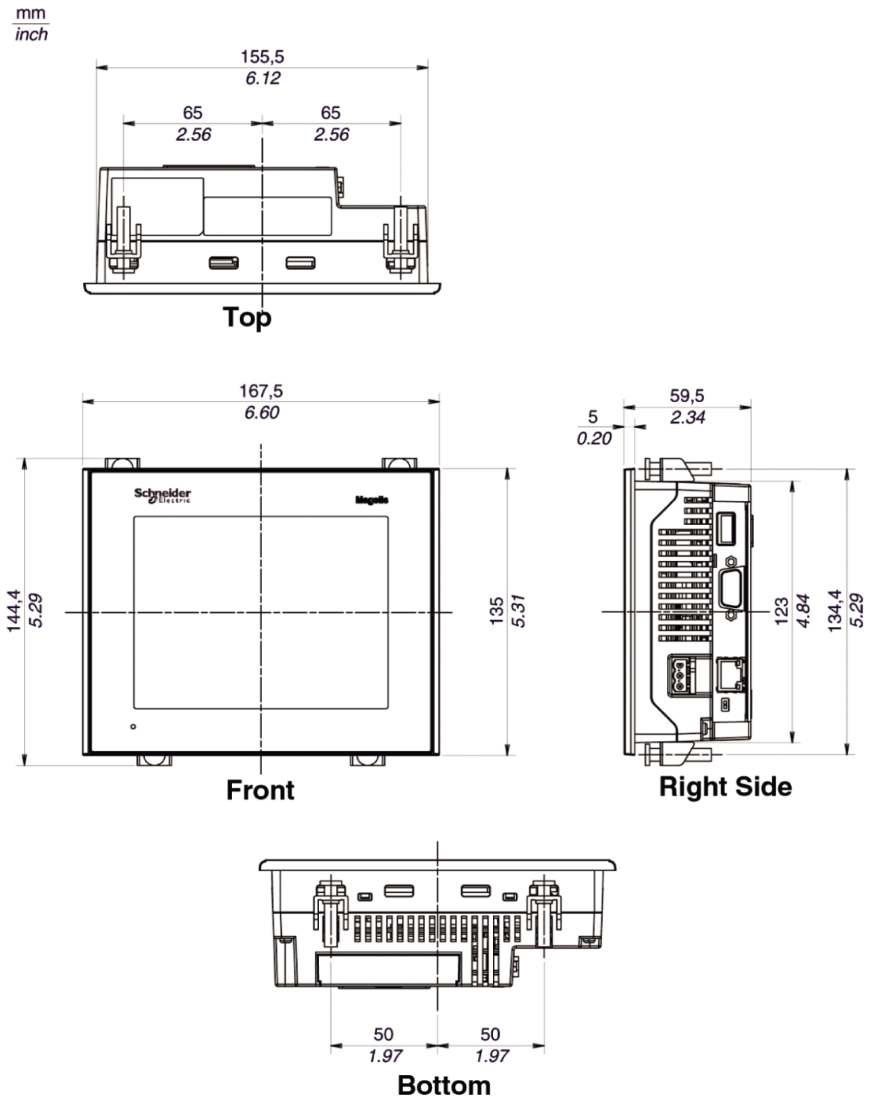

Dimensions of XBT GT2430

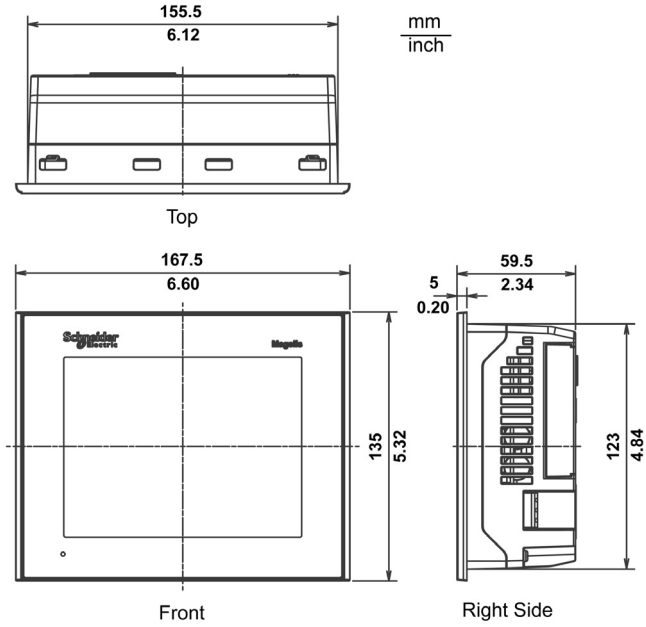

Dimensions of XBT GT2430 with Cables

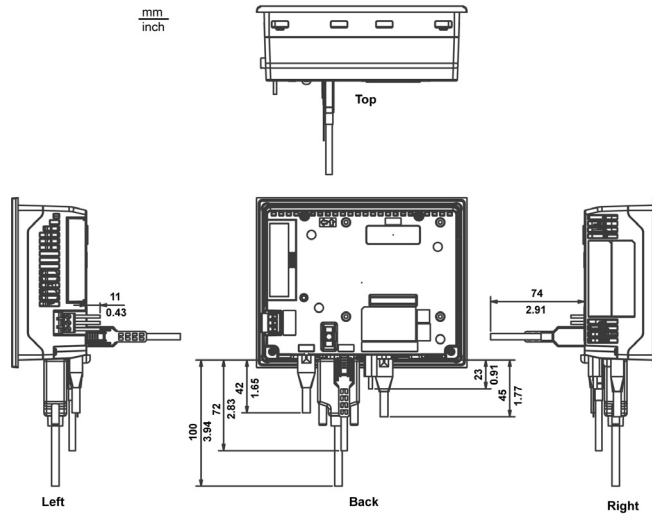

Installation of XBT GT2430 with Spring Clips

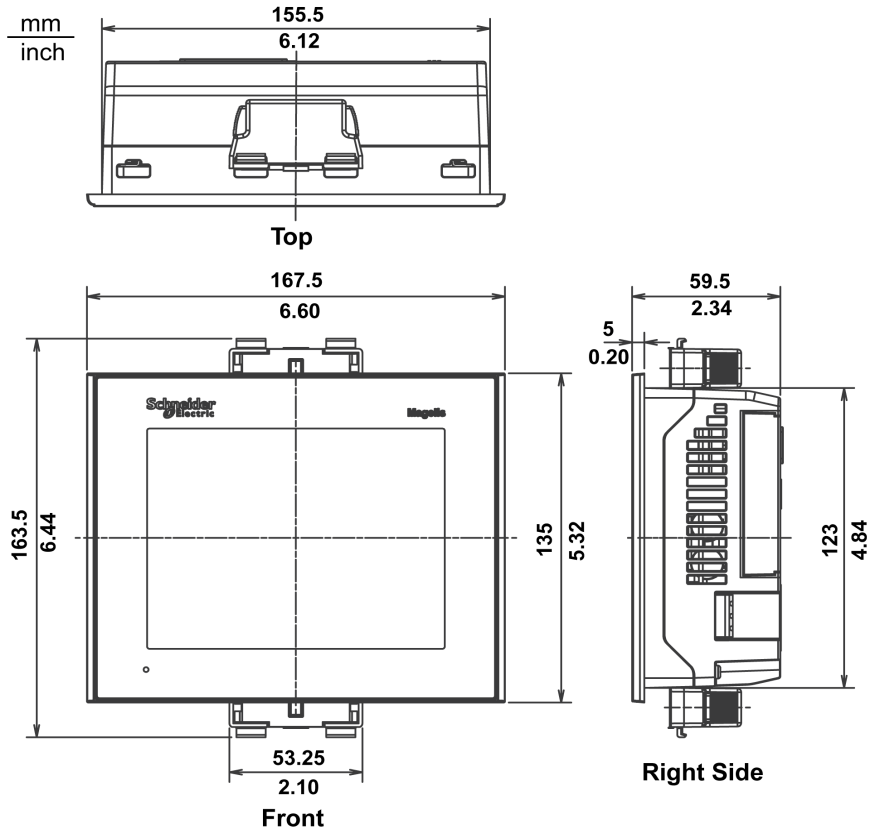

NOTE: Spring clip fasteners must be ordered separately (ref. XBT Z3002)

NOTE: Mounting XBT GT2430 with spring clips does not allow access to the COM1 and COM2 ports. If these ports are required, please use screw fasteners.

Installation of XBT GT2430 with Screw Fasteners

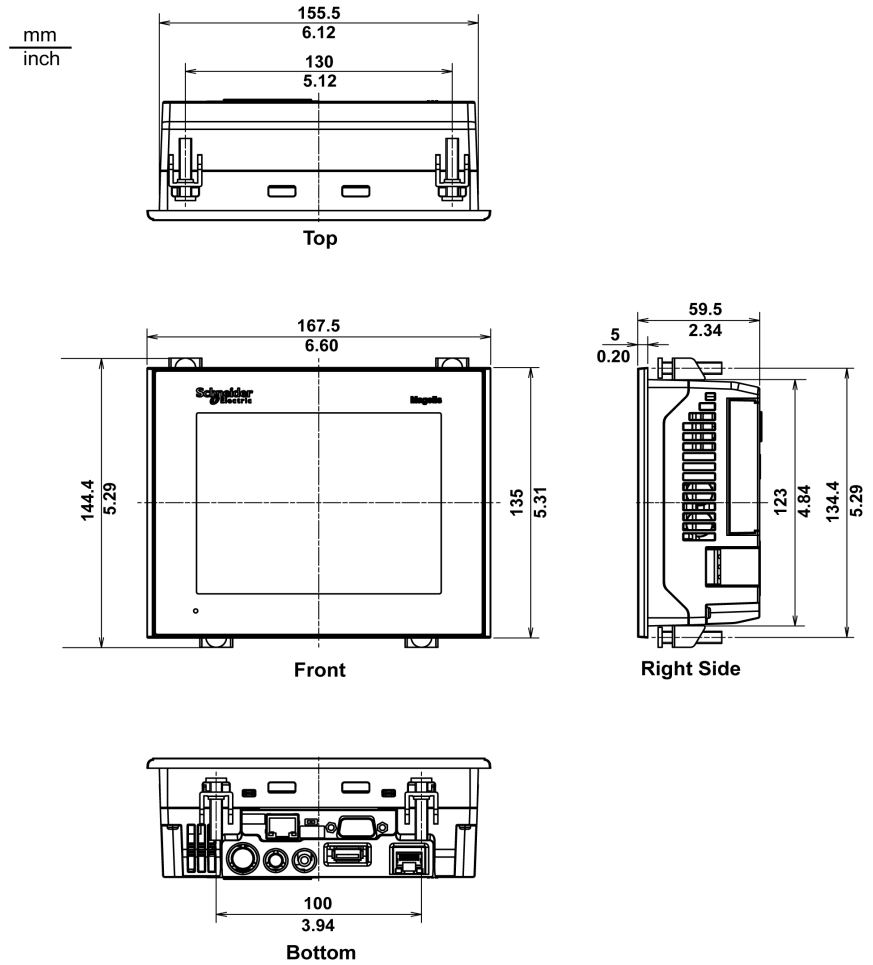

XBT GT4000 Series Dimensions

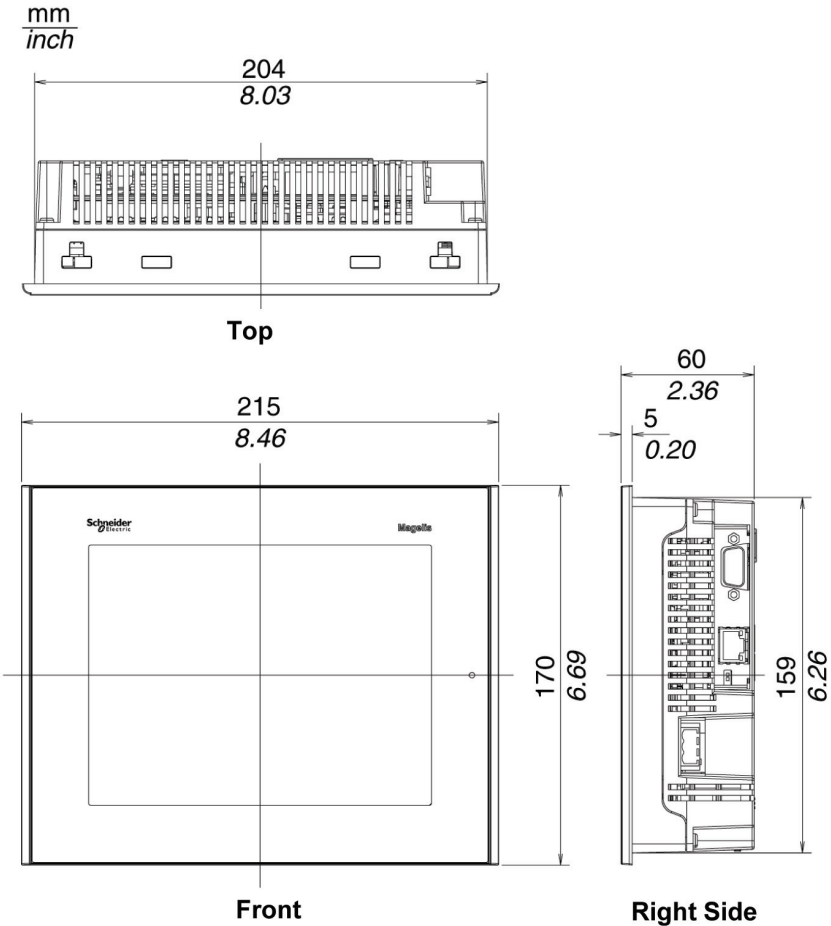

Dimensions with Cables

mm
in.

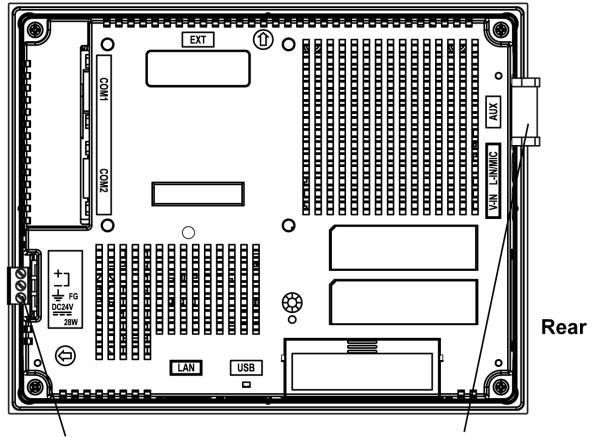

Power Connector

AUX Connector

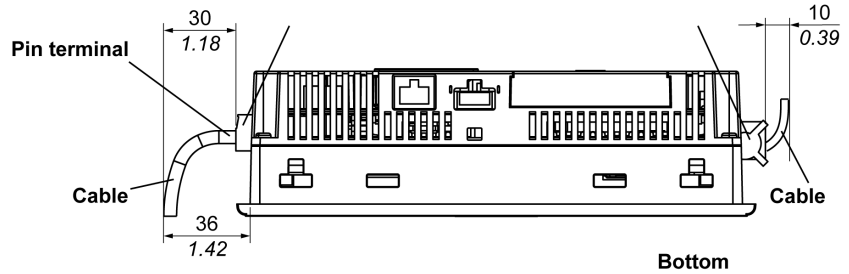

Installation with Spring Clips

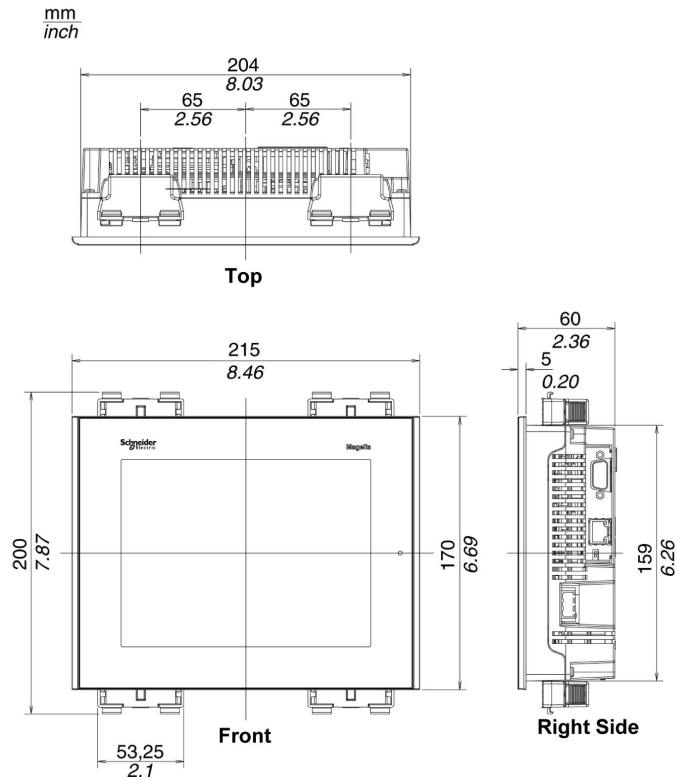

NOTE: XBT Z3002 spring clip fasteners must be ordered separately.

Installation with Screw Fasteners

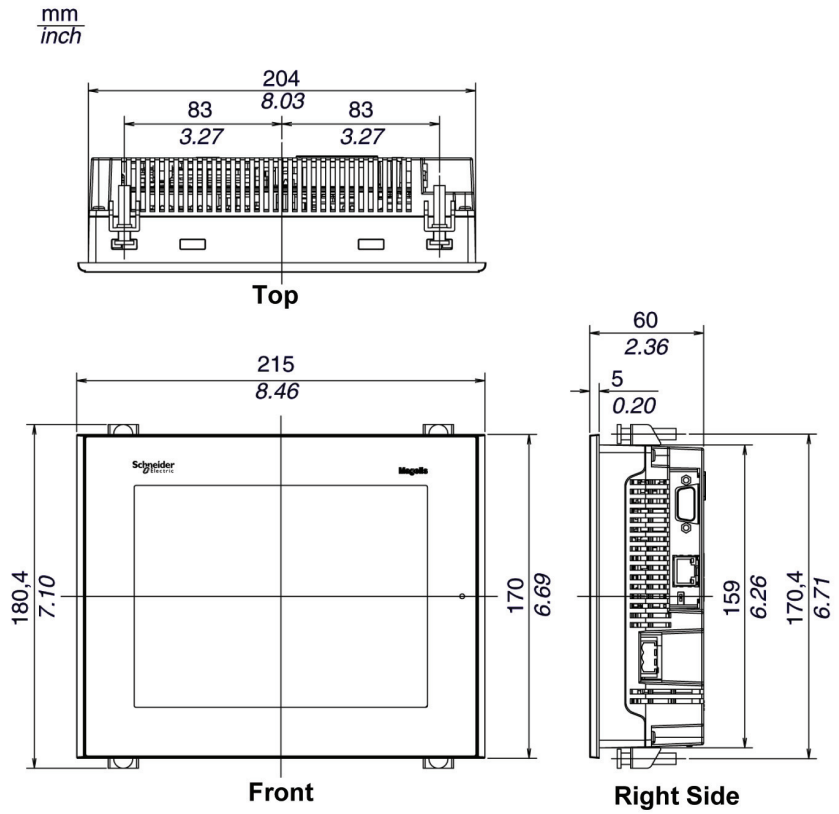

XBT GT5000 Series Dimensions

Dimensions of XBT GT5230

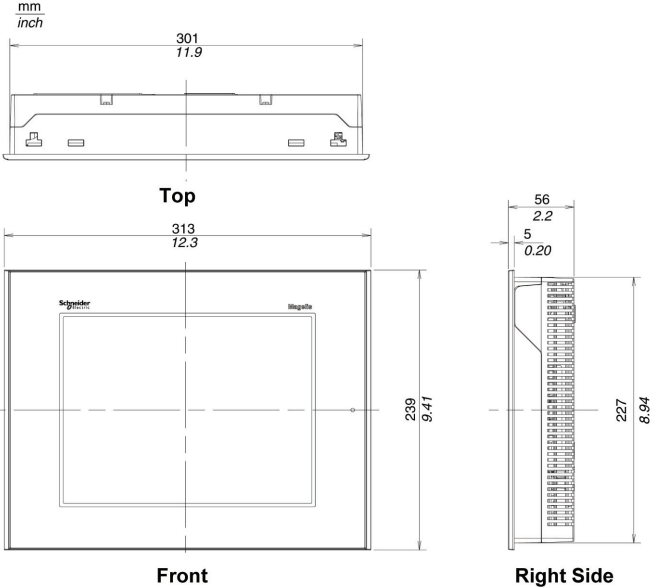

Dimensions of XBT GT5230 with Cables

$\frac{\text{mm}}{\text{in.}}$

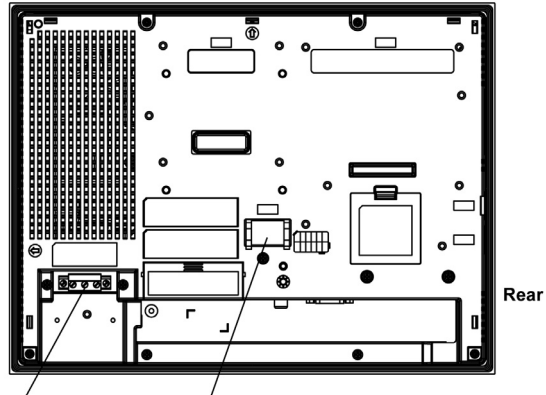

Power Connector

AUX Connector

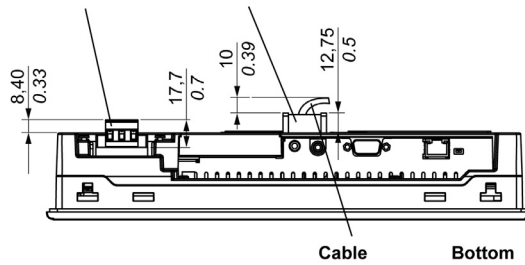

Cable

Bottom

Installation of XBT GT5230 with Spring Clips

mm
inch



Top

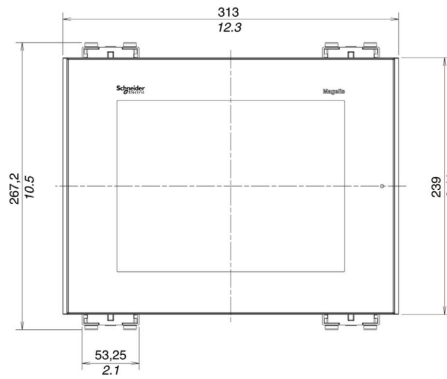

Front

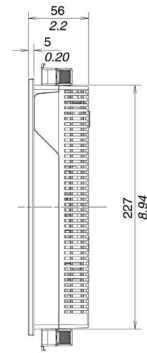

Right Side

NOTE: XBT Z3002 spring clip fasteners must be ordered separately.

Installation of XBT GT5230 with Screw Fasteners

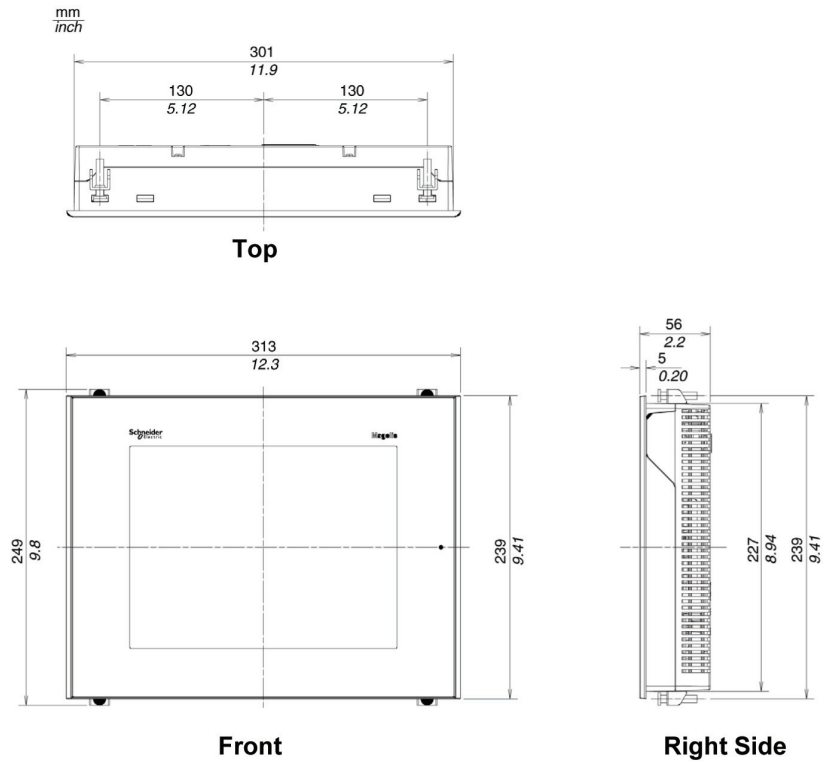

Dimensions of XBT GT5330/5340/5430

mm
inch



Top

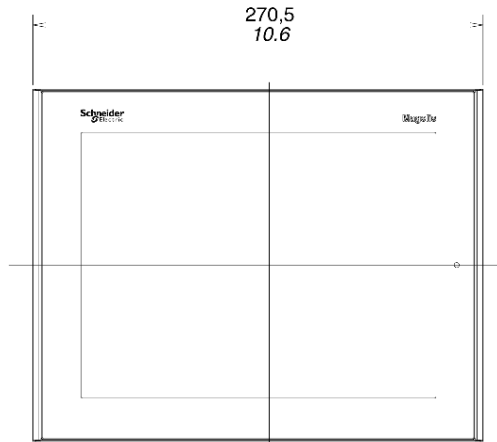

Front

212,5
8.37

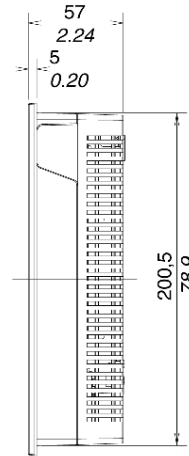

Right Side

Dimensions of XBT GT5330/5340/5430 with Cables

mm
in.

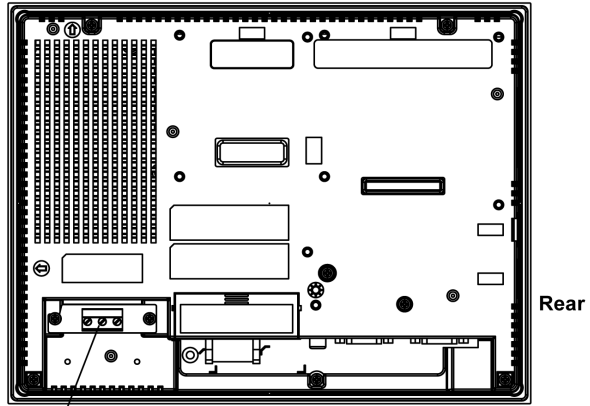

Power Connector

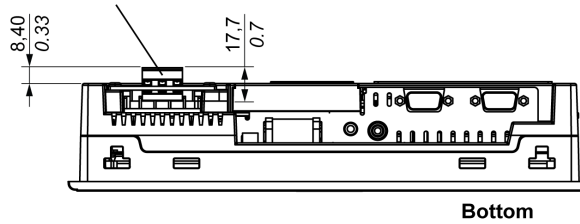

Installation of XBT GT5330/5340/5430 with Spring Clips

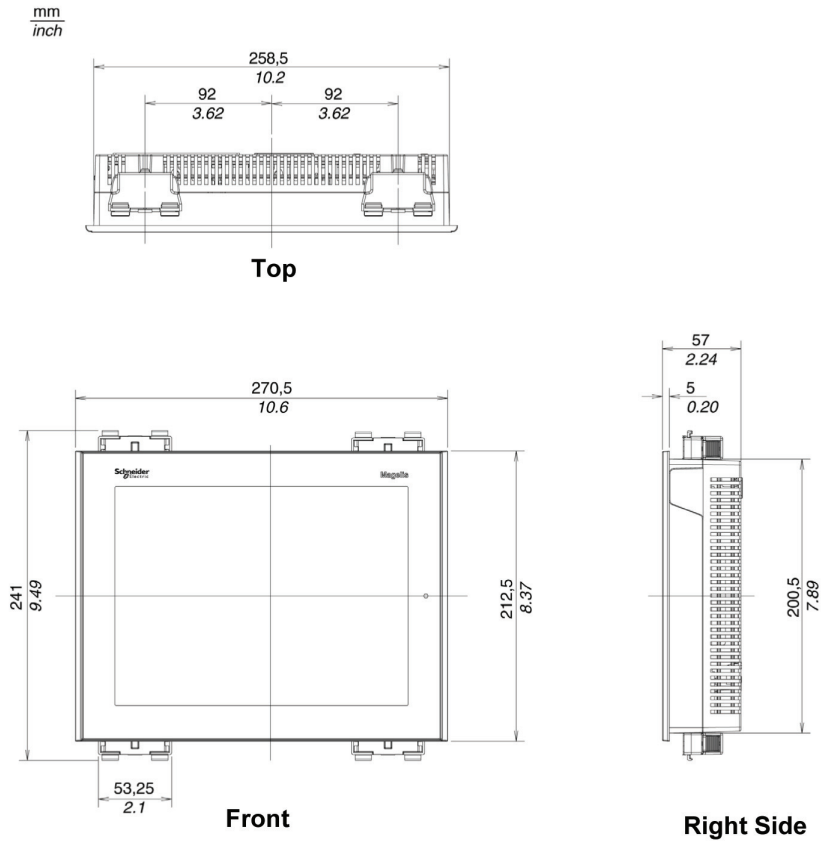

NOTE: XBT Z3002 spring clip fasteners must be ordered separately.

Installation of XBT GT5330/5340/5430 with Screw Fasteners

mm
inch

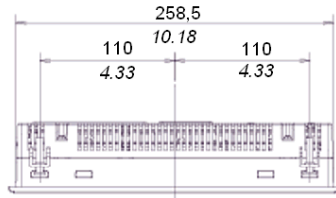

Top

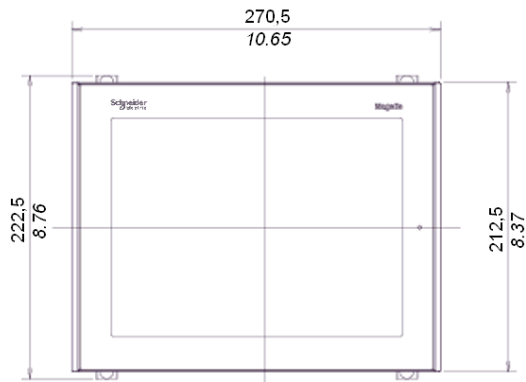

Front

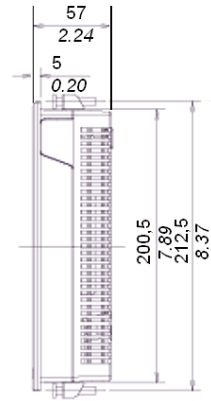

Right side

XBT GT6000 Series Dimensions

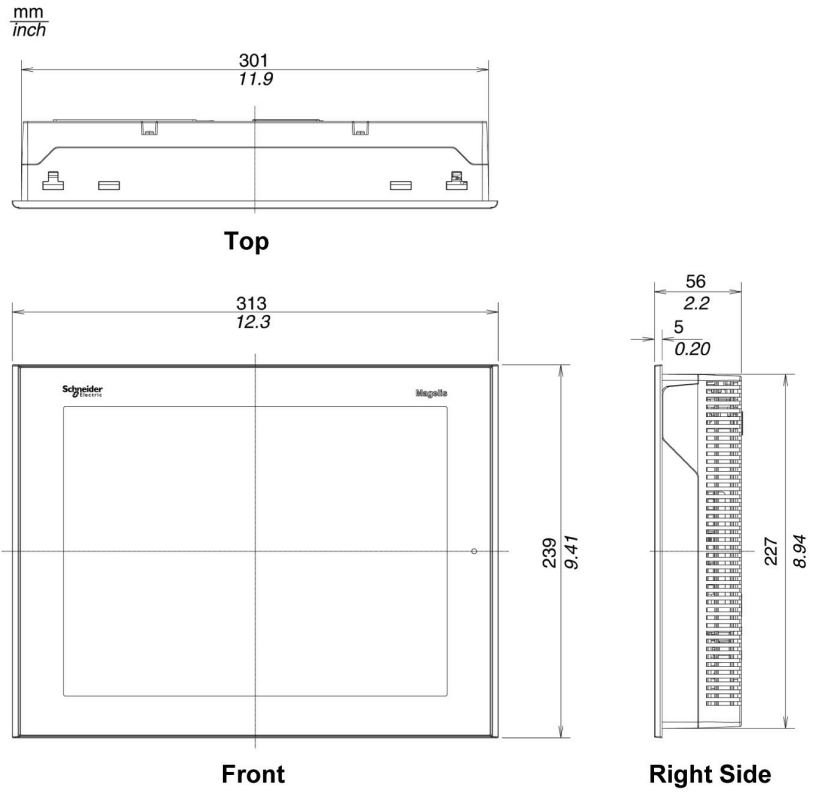

Dimensions with Cables

mm
in.

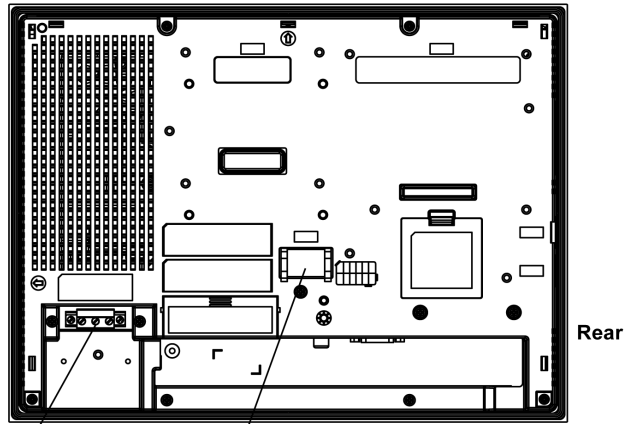

Power Connector

AUX Connector

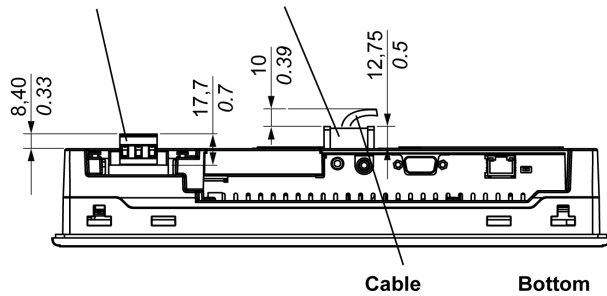

Cable

Bottom

Installation with Spring Clips

$\frac{\text{mm}}{\text{inch}}$

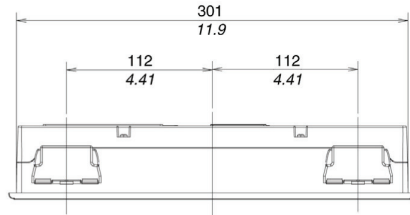

Top

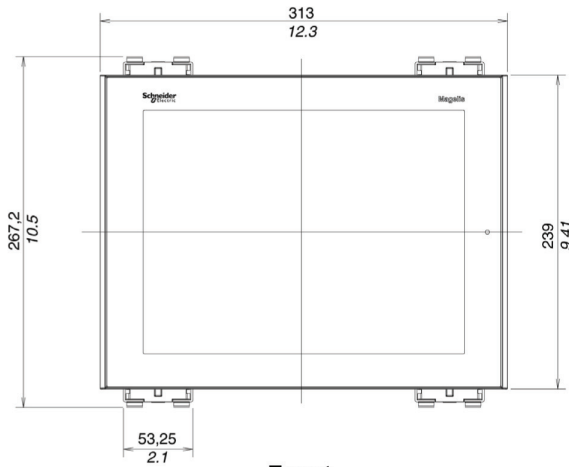

Front

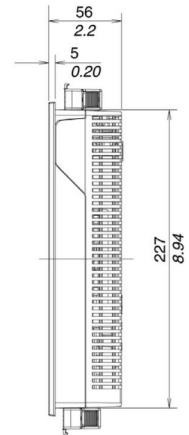

Right Side

NOTE: XBT Z3002 spring clip fasteners must be ordered separately.

Installation with Screw Fasteners

mm
inch

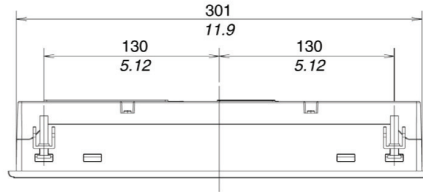

Top

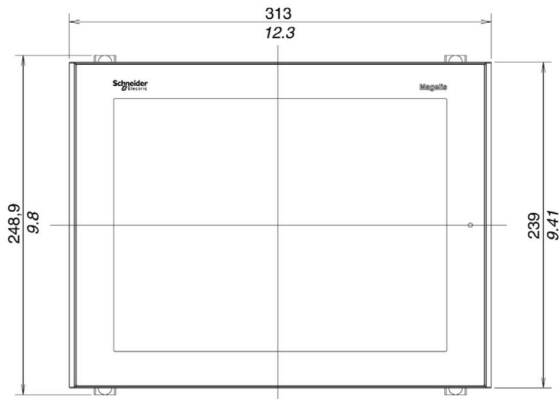

Front

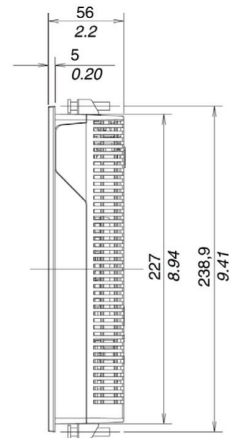

Right Side

XBT GT7000 Series Dimensions

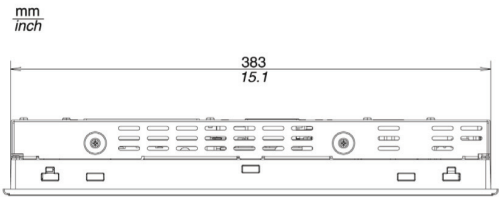

Top

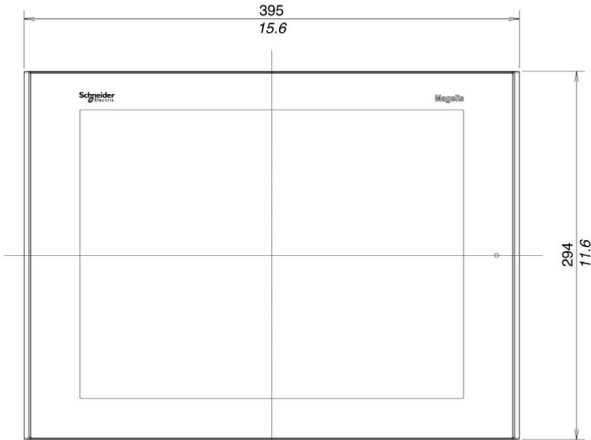

Front

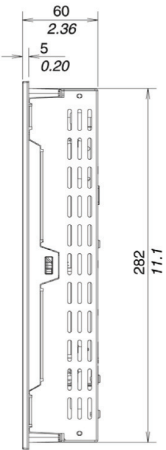

Right Side

Dimensions with Cables

$\frac{\text{mm}}{\text{in.}}$

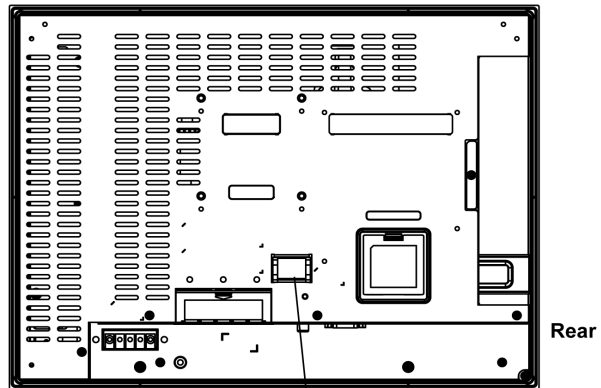

AUX Connector

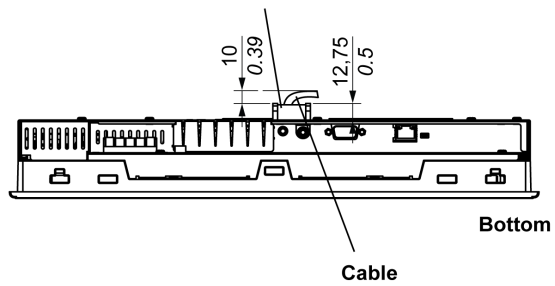

Installation with Spring Clips

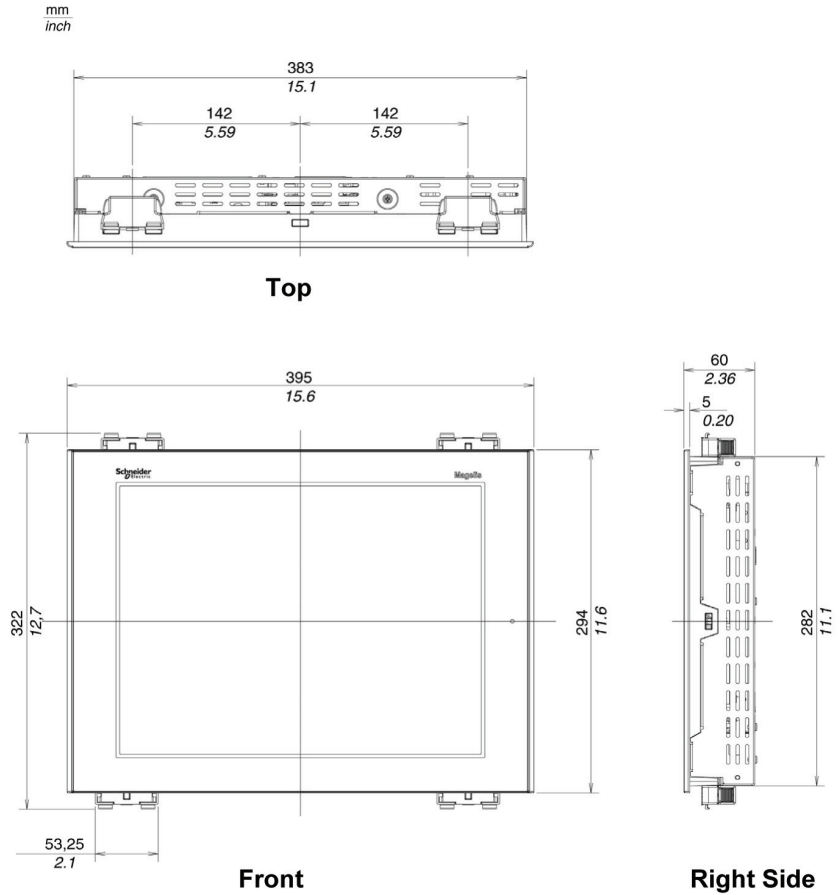

NOTE: XBT Z3002 spring clip fasteners have to be ordered separately.

Installation with Screw Fasteners

mm
inch

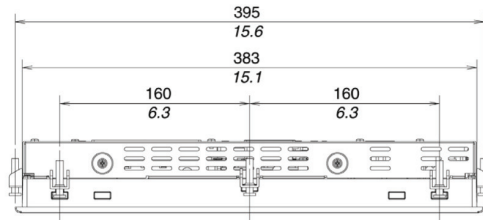

Top

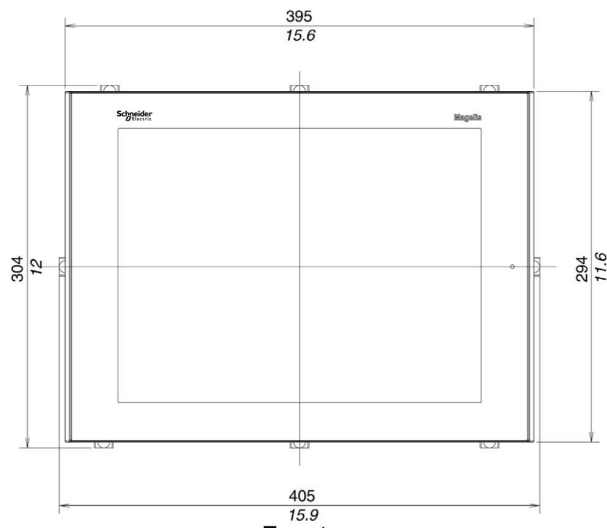

Front

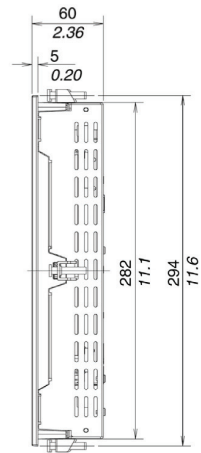

Right Side

XBT GK2000 Series Dimensions

The following illustrations show dimensions for the XBT GK2120 and 2330 keypad panels.

mm
in

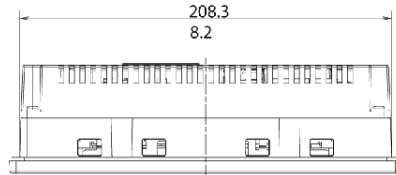

Top

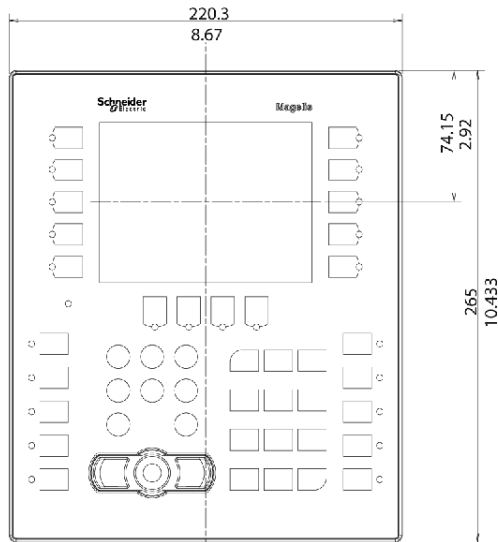

Front

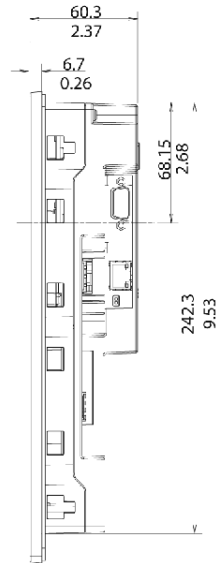

Right Side

Dimensions with Cables

$\frac{\text{mm}}{\text{inch}}$

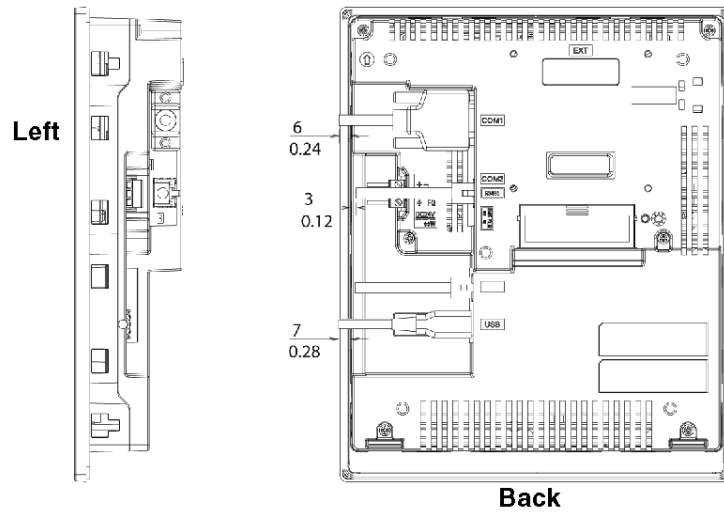

NOTE: The XBT GK2120 does not support Ethernet.

Installation with Spring Clips

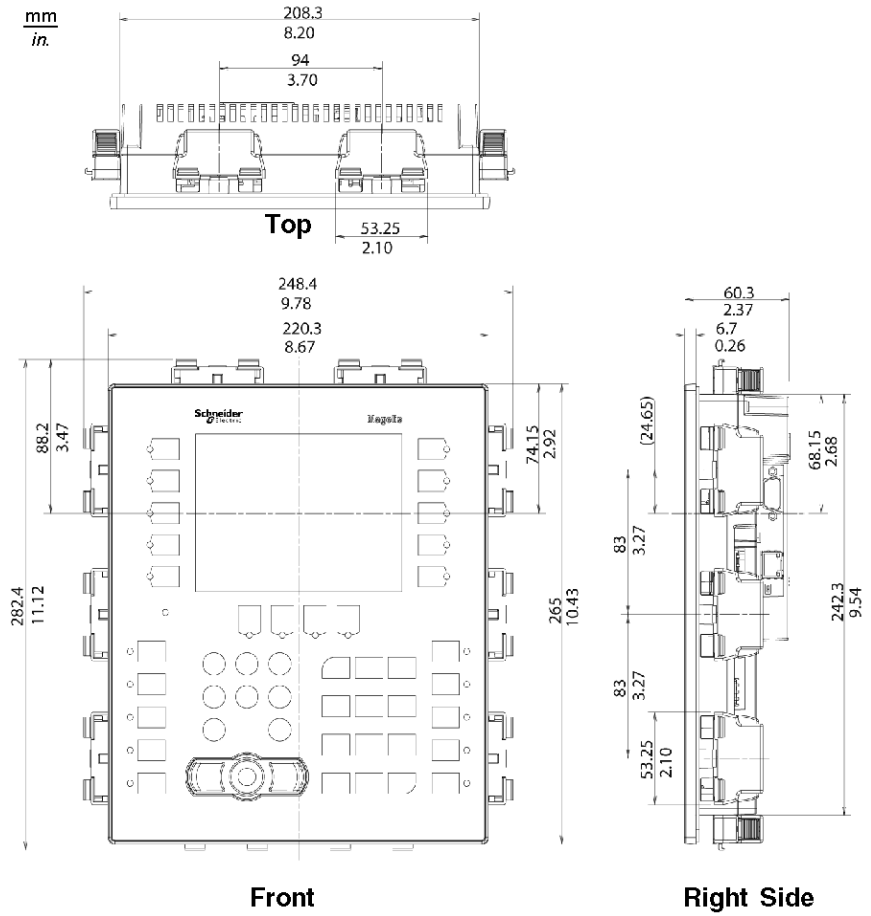

Installation with Screw Fasteners

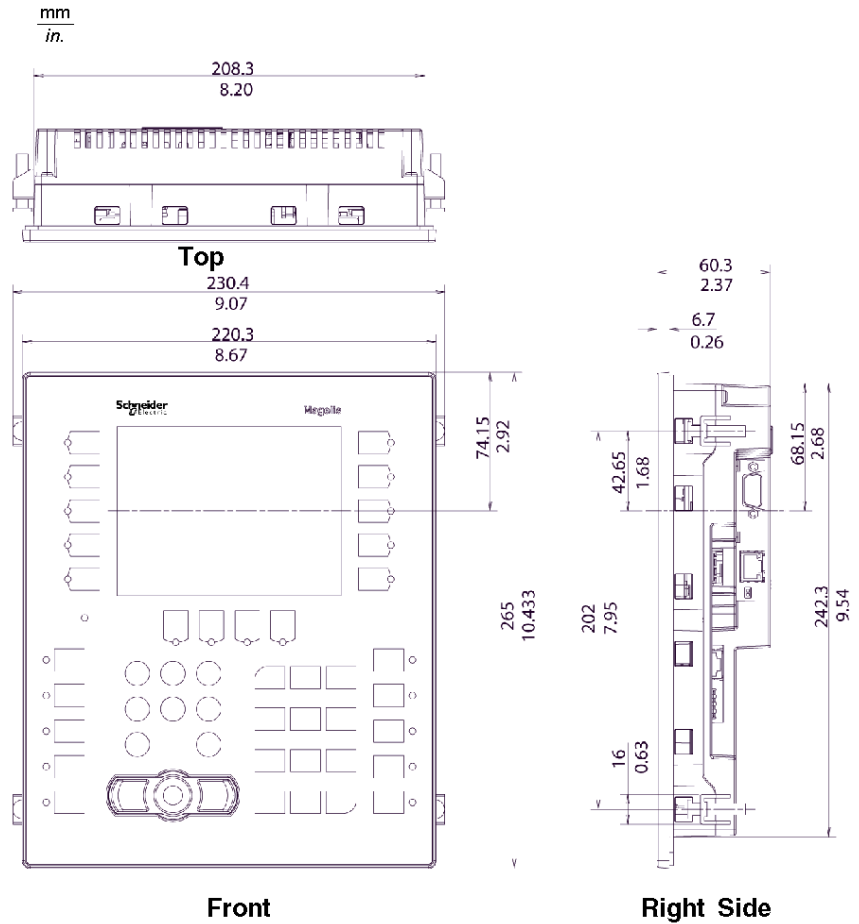

NOTE: XBT ZGFIX screw installation fasteners must be ordered separately.

XBT GK5330 Dimensions

Dimensions of XBT GK5330

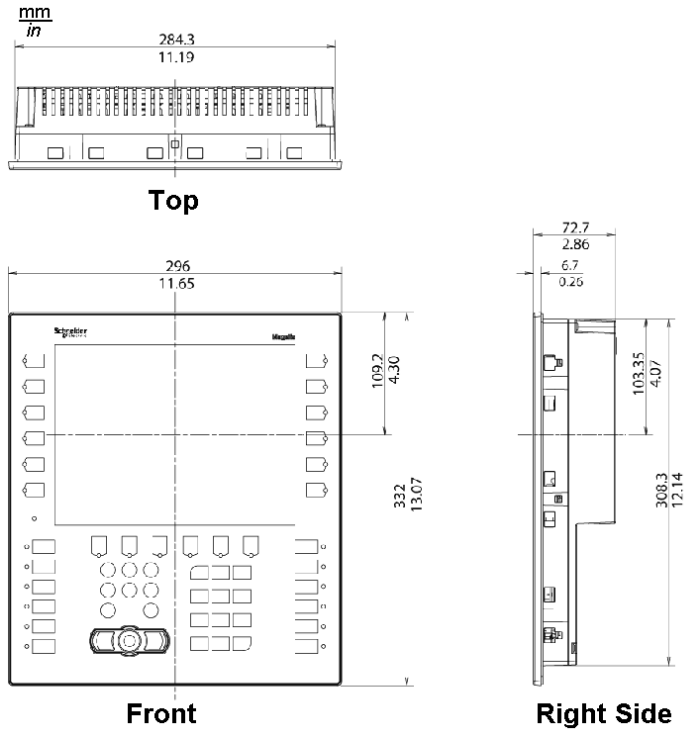

Dimensions of XBT GK5330 with Cables

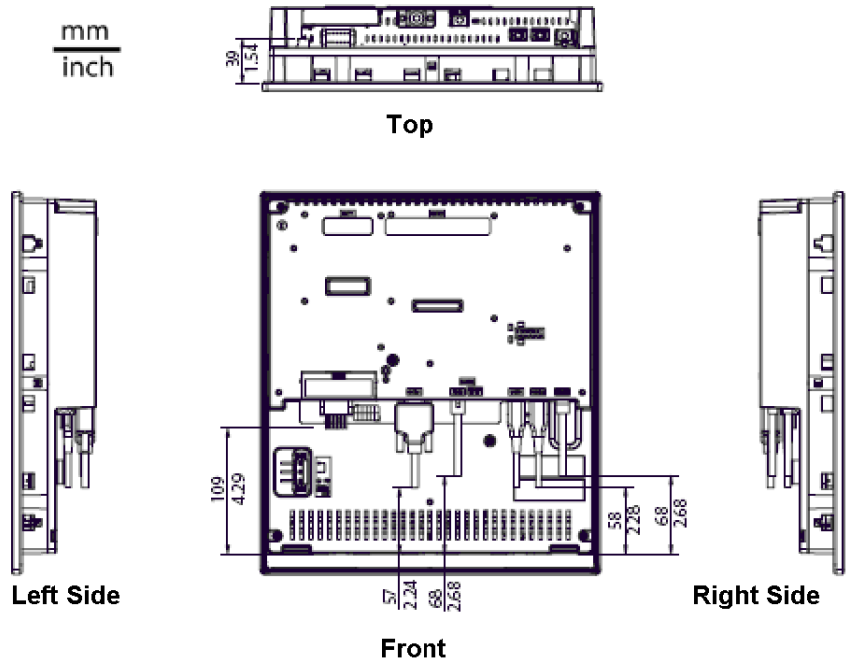

Installation of XBT GK5330 with Spring Clips

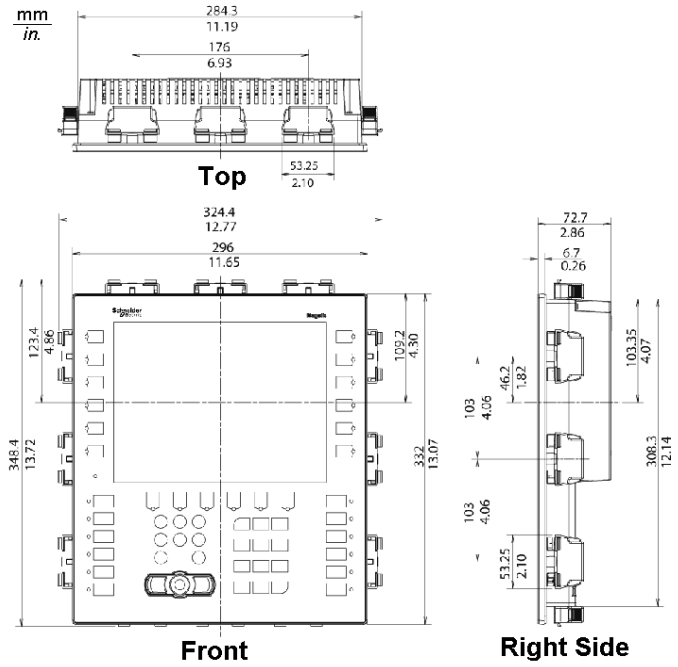

Installation of XBT GK5330 with Screw Fasteners

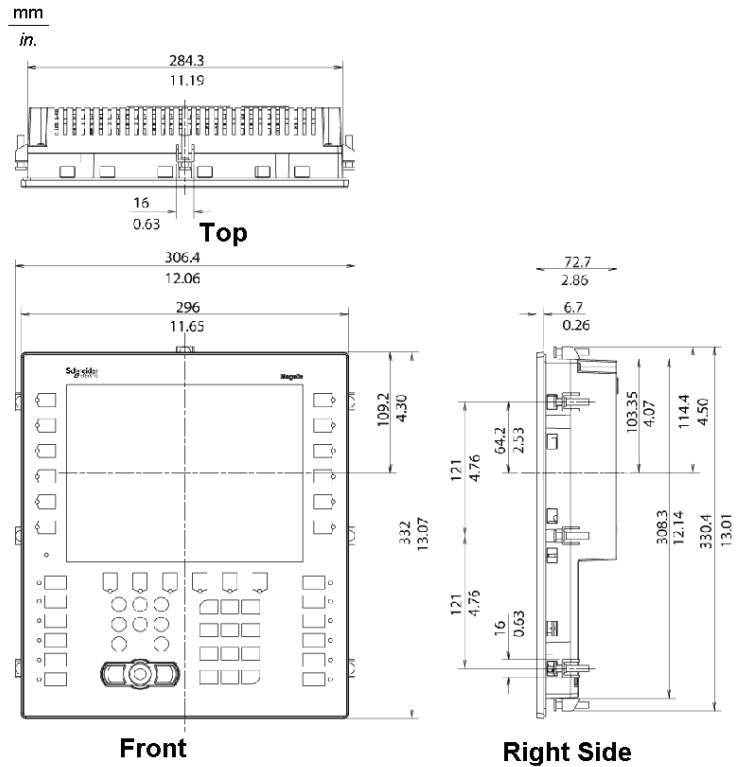

NOTE: XBT ZGFIX screw installation fasteners must be ordered separately.

XBT GH2000 Series Dimensions

Dimensions of XBT GH2460

The following illustrations show dimensions for the XBT GH2460 panels.

$\frac{\text{mm}}{\text{in.}}$

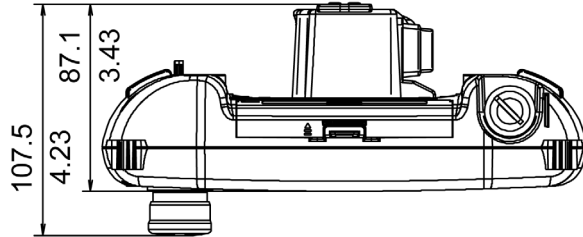

Top

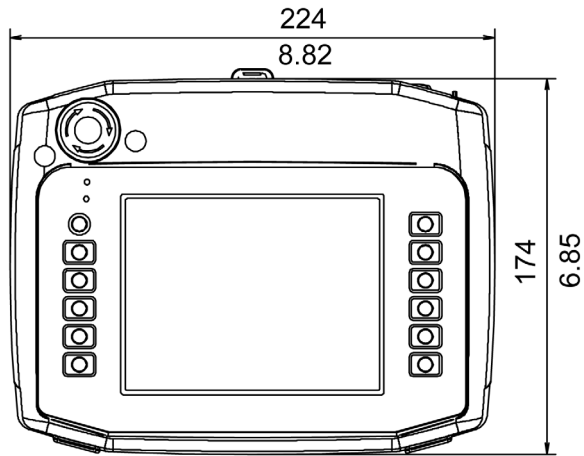

Front

Dimensions of the Emergency Switch Guard

$\frac{\text{mm}}{\text{in.}}$

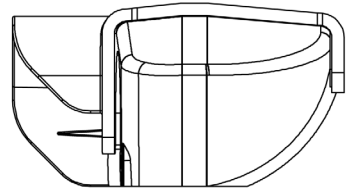
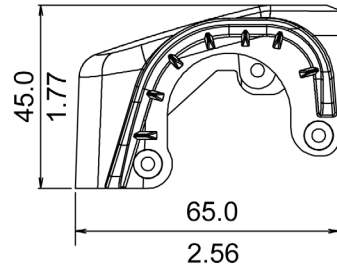
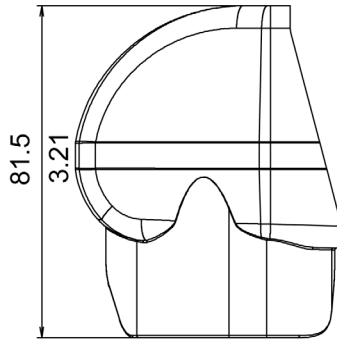

Panel Cut-out Dimension

Inserting a XBT GT/XBT GK

Create a panel cut-out and insert the unit into the panel from the front. The following illustration shows the panel cut-out for a XBT GT/XBT GK unit (example from the XBT GT1000 series).

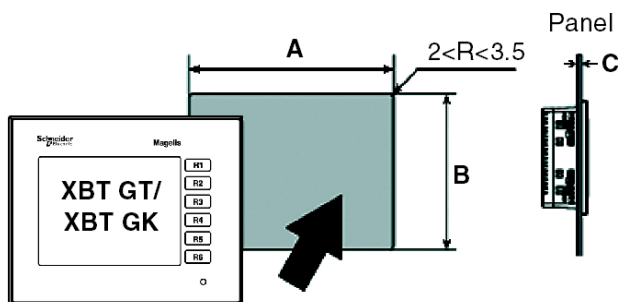

Dimensions

The following table shows the panel cut-out dimensions for each unit:

Unit	A	B	C Screw Installation Fastener	C Spring Clips
XBT GT1100 XBT GT1105 XBT GT1130 XBT GT1135 XBT GT1335	118.5 ^{+1/0} mm (4.67 ^{+0.04/0} in.)	92.5 ^{+1/0} mm (3.64 ^{+0.04/0} in.)	1.6...5 mm (0.06...0.20 in.)	1.5...6 mm (0.06...0.24 in.)
XBT GT2110 XBT GT2120 XBT GT2130 XBT GT2220 XBT GT2330 XBT GT2430 XBT GT2930	156 ^{+1/0} mm (6.14 ^{+0.04/0} in.)	123.5 ^{+1/0} mm (4.86 ^{+0.04/0} in.)	1.6...5 mm (0.06...0.20 in.)	1.5...6 mm (0.06...0.24 in.)
XBT GT4230 XBT GT4330 XBT GT4340	204.5 ^{+1/0} mm (8.05 ^{+0.04/0} in.)	159.5 ^{+1/0} mm (6.28 ^{+0.04/0} in.)	1.6...10 mm (0.06...0.39 in.)	1.5...6 mm (0.06...0.24 in.)
XBT GT5230	301.5 ^{+1/0} mm (11.87 ^{+0.04/0} in.)	227.5 ^{+1/0} mm (8.96 ^{+0.04/0} in.)	1.6...10 mm (0.06...0.39 in.)	1.5...6 mm (0.06...0.24 in.)
XBT GT5330 XBT GT5340 XBT GT5430	259 ^{+1/0} mm (10.20 ^{+0.04/0} in.)	201 ^{+1/0} mm (7.91 ^{+0.04/0} in.)	1.6...10 mm 0.06...0.39 in.	1.5...6 mm (0.06...0.24 in.)

Unit	A	B	C Screw Installation Fastener	C Spring Clips
XBT GT6330 XBT GT6340	301.5 ^{+1/0} mm (11.87 ^{+0.04/0} in.)	227.5 ^{+1/0} mm (8.96 ^{+0.04/0} in.)	1.6...10 mm (0.06...0.39 in.)	1.5...6 mm (0.06...0.24 in.)
XBT GT7340	383.5 ^{+1/0} mm (15.10 ^{+0.04/0} in.)	282.5 ^{+1/0} mm (11.12 ^{+0.04/0} in.)	1.6...10 mm (0.06...0.39 in.)	1.5...6 mm (0.06...0.24 in.)
XBT GK2120 XBT GK2330	209 ^{+/-0.4} mm (8.18 ^{+/-0.01} in.)	243 ^{+/-0.4} mm (9.52 ^{+/-0.01} in.)	1.5...6 mm (0.06...0.24 in.)	1.5...6 mm (0.06...0.24 in.)
XBT GK5330	285 ^{+/-0.4} mm (11.22 ^{+/-0.01} in.)	309 ^{+/-0.4} mm (12.17 ^{+/-0.01} in.)	1.5...6 mm (0.06...0.24 in.)	1.5...6 mm (0.06...0.24 in.)

Installation Fasteners

Introduction

Two types of fasteners can be used to mount the XBT GT and XBT GK ranges:

- screw installation fasteners,
- spring clips.

Unit	Spring Clips	Screw Installation Fasteners
XBT GT1000 series	2	4
XBT GT1005 series	2	4
XBT GT2000 series	2*	4
XBT GT4000 series	4	4
XBT GT5000 series	4	4
XBT GT6000 series	4	4
XBT GT7000 series	4	8
XBT GK2000 series	10	4
XBT GK5000 series	12	8

XBT GK series delivered with spring clips. XBT GT series delivered with screw installation fasteners.

* Mounting XBT GT2430 with spring clips does not allow access to the COM1 and COM2 ports. If these ports are required, please use screw fasteners.

Spring Clip Dimensions

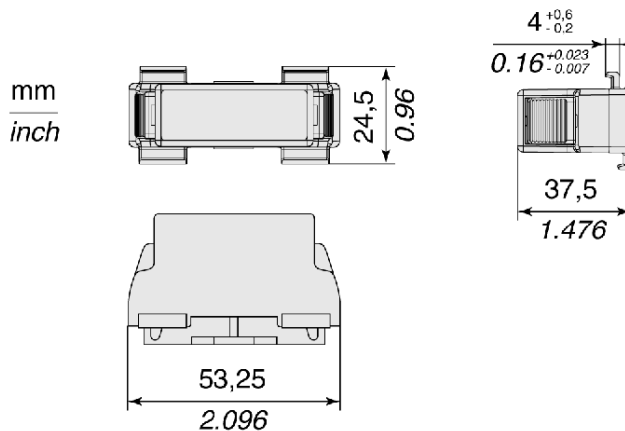

Screw Installation Fasteners Dimensions

mm
inch

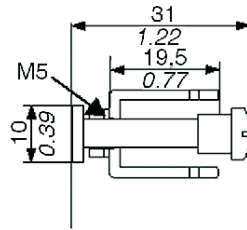
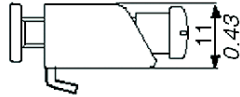
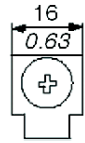

Installation and Wiring

4

Overview

This chapter describes the installation procedures and the wiring principles for XBT GT, XBT GK, and XBT GH.

What Is in This Chapter?

This chapter contains the following sections:

Section	Topic	Page
4.1	Installation	156
4.2	Wiring Principles	163
4.3	Tool Port Connector	172
4.4	Ethernet Cable Connector	177
4.5	CF Card	179
4.6	USB Port	182
4.7	AUX Connector	193
4.8	Cable Connector	194
4.9	Emergency Switch Guard	196

4.1 Installation

Installation Procedures

Introduction

Before installing the unit into a cabinet or panel, read the instructions below.

The installation gasket and installation fasteners (screw installation fasteners or spring clips) are required when installing the unit.

 CAUTION
--

IMPROPER USE

Do not use the cardboard display stand for industrial operation.
--

Failure to follow these instructions can result in injury or equipment damage.

Mount the terminal in an enclosure that provides a clean, dry, robust and controlled environment (IP65 enclosure) (*see page 38*).

NOTE: The protection level of the product may vary from that which is shown on the ATEX label, as the value on the ATEX label takes into account product aging.

An old gasket can lose its dust and drip resistance. Changing the gasket once a year or when scratches or dirt becomes visible is recommended.

Gasket setup requirements

The gasket helps maintain the protection ratings (IP65, IP20) of the unit, and provides additional protection from vibration.

Stage	Description
1	Before installing the unit into a cabinet or panel, check that the Installation gasket is securely attached to the unit.
2	A gasket which has been used for a long period of time may have scratches or dirt on its surface, and could have lost much of its dust and drip resistance. Change the gasket once a year or when scratches or dirt become visible.
3	Do not insert the joint of the installation gasket in the corner of the unit. Insert the joint only in the straight sections of the groove at the bottom of the product. If you insert the joint incorrectly, the joint will be pulled so that it may cause the installation gasket to be torn.

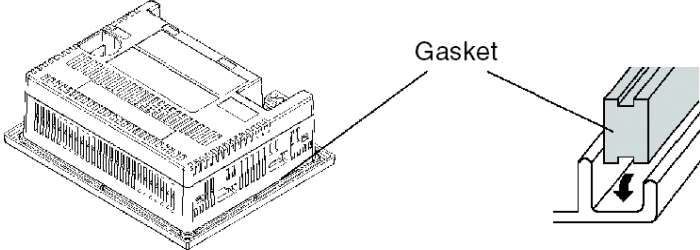
Stage	Description
4	<p>Make sure the gasket is inserted into the panel bottom face as shown in the following illustration:</p> 

⚠ WARNING

LOSS OF PANEL OR CABINET INGRESS PROTECTION RATING

- Insert the gasket correctly in the groove as described in this documentation.
- Do not stretch the gasket.
- Do not insert the gasket seam in groove corners.
- Only install the gasket seam in the straight section of the gasket groove at the bottom of the unit.
- Be sure that the upper surface of the gasket protrudes approximately 2.0 mm (0.08 in.) above the edge of the groove.

Failure to follow these instructions can result in death, serious injury, or equipment damage.

Panel setup procedure

Stage	Description
1	Check that the installation panel or cabinet's surface is flat, in good condition and has no jagged edges. Metal reinforcing strips may be attached to the inside of the panel, near the panel cut-out, to increase the panel's rigidity.
2	<p>Panel thickness depends on the unit. Decide the panel's thickness based on the level of panel strength required:</p> <ul style="list-style-type: none"> ● 1.6...5 mm (0.06...0.2 in.) for XBT GT1000/1005/2000 ● 1.6...10 mm (0.06...0.4 in.) for XBT GT4000/5000/6000/7000 ● 1.6...6 mm (0.06...0.24 in.) for XBT GK
3	Be sure that the ambient operation temperature and the ambient humidity are within their designated ranges. (When installing the unit in a cabinet or enclosure, the ambient operation temperature is the cabinet's or enclosure's internal temperature.)

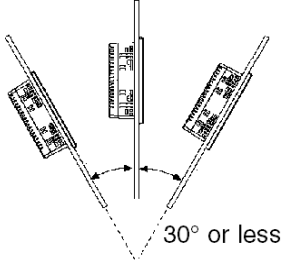
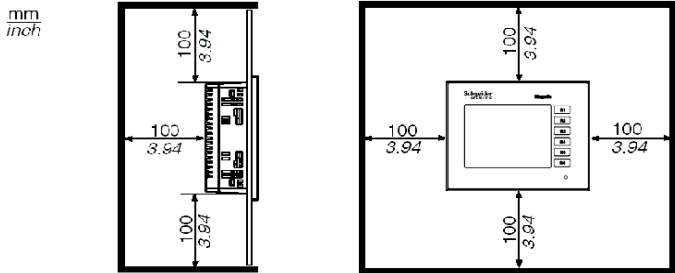
Stage	Description
4	Be sure that heat from surrounding equipment does not cause the unit to exceed its standard operating temperature (see page 38).
5	<p>When installing the unit in a slanted panel, the panel face should not incline more than 30° .</p>  <p>When installing the unit in a slanted panel, and the panel face inclines more than 30° , the ambient temperature must not exceed 40 °C (104 °F). You may need to use forced air cooling (fan, A/C) to ensure the ambient operating temperature is 40 °C (104 °F) or below.</p>
6	When installing the unit vertically, position the unit so that the power plug is also vertical.
7	When installing the unit in enclosure type 4 compliant environment, use only the installation fasteners supplied with the unit (screw installation fasteners for XBT GT series and spring clips for XBT GK series).
8	<p>For easier maintenance, operation and improved ventilation, install the unit at least 100 mm (3.94 in.) away from adjacent structures and other equipment as shown in the following illustrational:</p>  <p><i>mm</i> <i>inch</i></p>

Installation with Spring Clips

⚠ CAUTION

SPRING LOADED MECHANISM

Do not release spring clip mechanism near face.

Failure to follow these instructions can result in injury or equipment damage.

⚠ CAUTION

TERMINAL UNSTEADY WHEN UNSECURED

Keep terminal stabilized in the panel cut-out while you are installing or removing the spring clips.

Failure to follow these instructions can result in injury or equipment damage.

NOTE: Use the installation gasket to absorb vibration and to repel water.

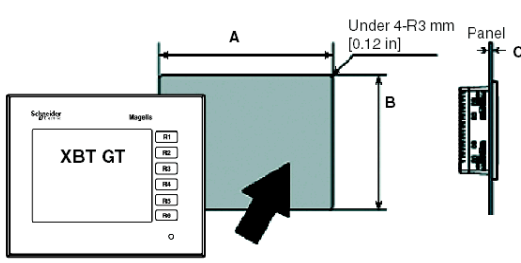
Step	Action
1	Place the unit on a clean and level surface with the display panel facing downward.
2	Check that the unit's installation gasket (<i>see page 216</i>) is seated securely into the gasket's groove, which runs around the perimeter of the panel's frame.
3	Create the correct sized opening required to install the unit, using the installation dimensions (<i>see page 151</i>).
4	Insert the unit (example from the XBT GT1000 series) into the panel cut-out:. 

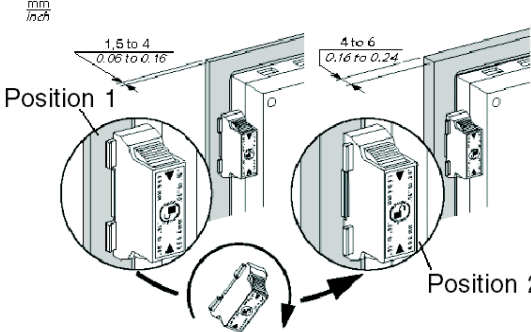
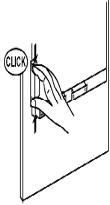
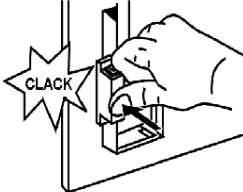
Step	Action
5	<p>Adjust the spring clips for the panel thickness:</p> <ul style="list-style-type: none"> ● 1.5 mm (0.06 in.) \leq panel thickness \leq 4 mm (0.16 in.) (position 1), ● 4 mm (0.16 in.) \leq panel thickness \leq 6 mm (0.23 in.) (position 2). 
6	<p>Lock the spring clips by pressing simultaneously on the top and the bottom with two fingers.</p> 
7	<p>To remove the spring clips:</p> <ul style="list-style-type: none"> ● Unlock the spring clips by pressing on the back: 

NOTE: Spring clips fasteners are required for NEMA Type 4 protection for XBT GK series.

Installation with Screw Fasteners

⚠ CAUTION

TERMINAL UNSTEADY WHEN UNSECURED

Keep terminal stabilized in the panel cut-out while you are installing or removing the spring clips.

Failure to follow these instructions can result in injury or equipment damage.

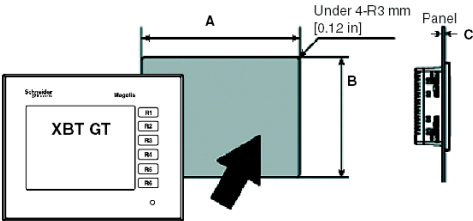
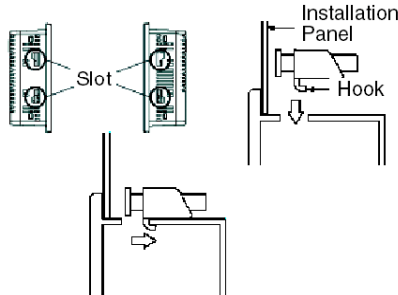
Step	Action
1	Place the unit on a clean and level surface with the display panel facing downward.
2	Check that the unit's installation gasket (<i>see page 216</i>) is seated securely into the gasket's groove, which runs around the perimeter of the panel's frame.
3	Create the correct sized opening required to install the unit, using the installation dimensions (<i>see page 151</i>).
4	Insert the unit (example from the XBT GT1000 series) into the panel cut: 
5	Insert the installation fasteners into the unit's insertion slots situated on the left and right side of the unit and slide them to the back. If the fasteners are not correctly attached, the unit may shift or fall out of the panel: 

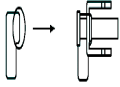
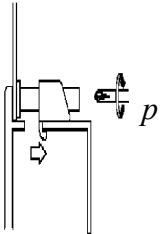
Step	Action
6	<p>Be sure to insert installation fasteners in the recessed portion of an installation fastener's hole:</p> 
7	<p>Use a Phillips screwdriver to tighten each fastener screw and secure the unit in place. The necessary torque is 0.5 Nm (4.4 lb-in):</p> 

⚠ CAUTION

BROKEN ENCLOSURE

Do not exert more than 0.5 Nm (4.4 in-lb) of torque when tightening the fastener's screws. Tightening the screw with excessive force can damage the unit's plastic case.

Failure to follow these instructions can result in injury or equipment damage.

NOTE: Screw installation fasteners are required for NEMA Type 4 protection for XBT GT series.

4.2 Wiring Principles

Overview

This section presents XBT GT and XBT GK wiring principles.

What Is in This Section?

This section contains the following topics:

Topic	Page
Connecting the Power Cord	164
Connecting the Power Supply	167
Grounding	169
Input/Output Line Placement	171

Connecting the Power Cord

Introduction

Follow these instructions when supplying power to the unit.

NOTE:

- When the frame ground (FG) terminal is connected, be sure the wire is grounded. Not grounding the unit can result in excessive Electromagnetic Interference (EMI). Grounding is required to meet EMC level immunity.
- The shield ground (SG) and FG terminals are connected internally in the unit.

NOTE:

- Remove power before wiring to the power terminals of the unit.
- The unit uses only 24 Vdc power. Using any other level of power can damage both the power supply and the unit.
- Since the unit is not equipped with a power switch, be sure to connect a power switch to the unit's power supply.
- Be sure to ground the unit's FG terminal.

Power Cord Preparation

NOTE:

- Make sure the ground wire is the same gauge or heavier than the power wires.
- Do not use aluminum wires in the power cord for power supply.
- If the conductor's end (individual) wires are not twisted correctly, the end wires may either short loop to each other or against an electrode. To avoid this, use D25CE/AZ5CE cable ends.
- Wherever possible, use wires that are $0.2...2.5 \text{ mm}^2$ (24 - 12 AWG) for the power cord, and twist the wire ends before attaching the terminals.
- The conductor type is solid or stranded wire.

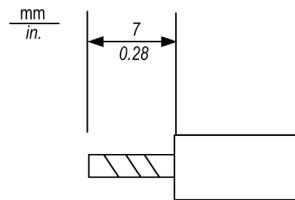

Power Plug Illustration

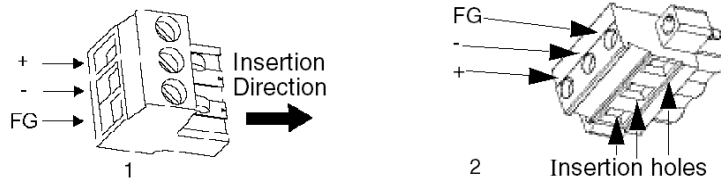

- 1 Power plug for XBT GT1000/1005/2000/4000 series and XBT GK2000 series
- 2 Power plug for XBT GT5000/6000/7000 series and XBT GK5000 series

Connection	Wire
+	24 Vdc
-	0 Vdc
FG	Grounded terminal connected to the unit chassis.

How to connect the Power Cord

The following table explains how to connect the power plug:

Step	Action
1	Remove the power cord from the power supply.
2	Remove the power plug from unit.
3	Remove 7 mm (0.28 in.) of the vinyl cover of each of the power cord's wires.
4	If using stranded wire, twist the ends. Tinning the ends with solder reduces risk of fraying and ensures good electrical transfer.
5	Connect the wires to the power plug by using flat-blade screwdriver (Size 0.6 x 3.5)
6	Torque the mounting screws: 0.5...0.6 nm (5...7 lb-in)
7	Replace the power plug to the power connector.

NOTE:

- Do not solder the wire directly to the power receptable pin.
- The power supply cord should meet the specification shown above. Be sure to twist the power cords together, up to the power plug, for EMC cancellation. (See illustration as shown below)

Example of Power Cord's Connection

The following illustration displays a connection's example of the power cord on the XBT GT1000 series:

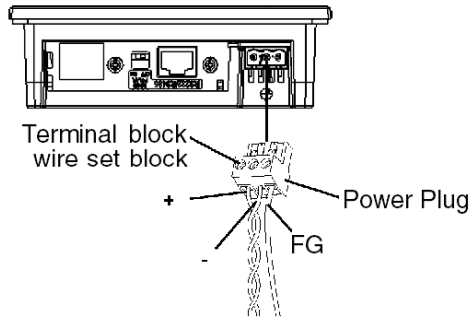

Connecting the Power Supply

Precautions

- Connect the power cord to the power connector on the side of the unit using the power plug.
- Between the line and the ground, be sure to use a regulated power supply with a Class 2 power supply
- To increase the electromagnetic noise resistance, be sure to twist the ends of the power cord wires before connecting them to the power plug.
- The unit's power supply cord should not be bundled with or kept close to main circuit lines (high voltage, high current), or input/output signal lines.
- Connect a lightning surge absorber to handle power surges.
- To reduce electromagnetic noise, make the power cord as short as possible.

WARNING

SHORT CIRCUITS, FIRE, OR UNINTENDED EQUIPMENT OPERATION

Excessive stress on the power connection or attempting to install a unit with the power cables connected may disconnect or cause damage to the power connections, which can cause short circuits, fire or unintended equipment operation.

Avoid excessive force on the power cable to prevent accidental disconnection.

- Securely attach power cables to the panel or cabinet.
- Use the designated torque to tighten the unit's terminal block screws.
- Install and fasten unit on installation panel or cabinet prior to connecting Power Supply and Communication lines.

Failure to follow these instructions can result in death, serious injury, or equipment damage.

Power Supply Connections

For ease of maintenance, use the following optional connection diagram to set up your power supply connections.

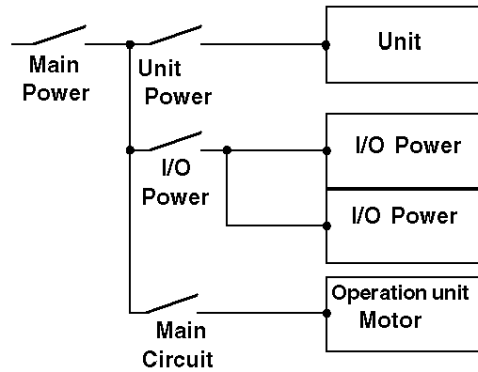
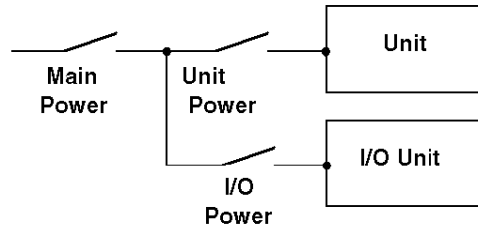

NOTE:

- Ground the surge absorber (E1) separately from the unit (E2).
- Select a surge absorber that has a maximum circuit voltage greater than that of the peak voltage of the power supply.

The following displays a lightning surge absorber connection:

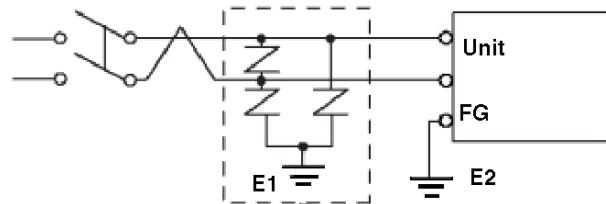

Grounding

Take the following precautions for grounding the unit.

Exclusive Grounding

Connect the frame ground (FG) terminal on the power plug to an exclusive ground.

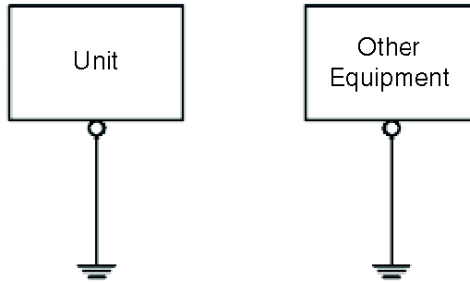

Grounding Procedure

Step	Action
1	Check that the grounding resistance is less than 100 Ω (1).
2	The FG wire should have a cross sectional area greater than 2 mm (0.08 in.) (1). Create the connection point as close to the unit as possible, and make the wire as short, as possible. When using a long grounding wire, replace the thin wire with a thicker wire, and place it in a duct.
3	If the equipment does not function properly when grounded, disconnect the ground wire from the FG terminal.
(1) Observe local codes and standards. Ensure the ground connection has a resistance of less than 100 Ω and that the ground wire has a cross-section of at least 2 mm ² or 14 AWG.	

Common Grounding

Precautions:

Electromagnetic Interference (EMI) can be created if the devices are improperly grounded. Electromagnetic Interference (EMI) can cause loss of communication.

Do not use common grounding, except for the authorised configuration described below.

If exclusive grounding is not possible, use a common connection point.

Correct grounding

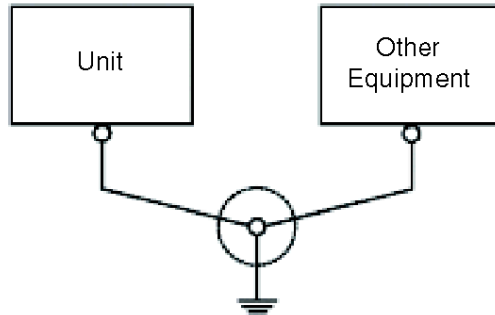

Incorrect grounding

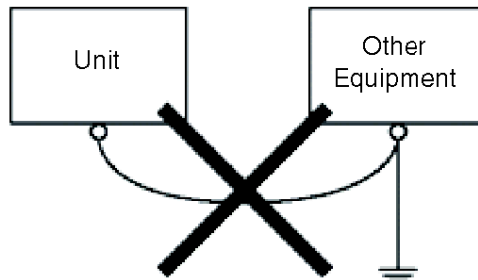

Input/Output Line Placement

Introduction

Input and output signal lines must be separated from the power supply cables for operating circuits.

If this is not possible, use a shielded cable and connect the shield to the unit's FG terminal.

4.3 Tool Port Connector

Overview

This section describes the Tool Port Connector Installation.

What Is in This Section?

This section contains the following topics:

Topic	Page
Making Tool Port Connections	173
USB Driver Installation	174

Making Tool Port Connections

Introduction

The XBTZG915 and XBTZG925 data transfer cables can be attached to the tool port on XBT GT1000 Series units to allow transferring of data from the computer to the XBT GT. See *Parts Identification and Functions*, page 73.

⚠ CAUTION

LIVE VOLTAGE

Unplug the XBT GT unit's power cord from the 24 Vdc power supply prior to attaching or detaching any connector(s) to or from the XBT GT.

Failure to follow these instructions can result in injury or equipment damage.

Tool Port Connector Location

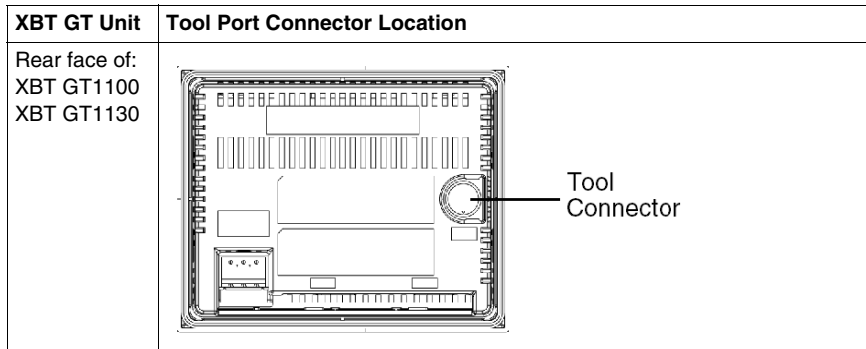

USB Driver Installation

Introduction

Use the USB data transfer cable to download data from a PC running Vijeo Designer to the unit. It connects to the tool port of the unit.

Installation Requirements

PC, Microsoft Windows 2000 (SP4 and up), XP (SP2 and up), and Vista Business operating system (OS).

Vijeo Designer Installation CD.

Consider the following when installing the USB driver:

- Do not connect the USB data transfer cable until told to do so in the instructions.
- When connecting the USB data transfer cable to the PC or to the unit, insert the cable's connector at the correct 90° angle.
- When disconnecting the cable, make sure to hold the connector, not the cable itself.
- If the installation does not complete successfully, restart the PC and quit all resident applications before re-installing the software.

NOTE: Vijeo Designer must be installed before installing the USB driver.

Installation Procedure for Windows 2000, XP, and Vista

Step	Action
1	Insert the Vijeo Designer Installation CD-ROM into your CD-ROM drive. The Setup window for Vijeo Designer should open automatically. If not, at the Windows Start menu, click Run and type x:\install.exe (where x is your CR-ROM drive letter).
2	In the install menu, select USB Driver .
3	Select the driver you want to install from the window that appears. For the XBT ZG925 USB cable, select Install USB driver for XBTG/XBTGT1000 Series .
4	A popup window appears stating that the installation of the driver was successful.
5	Connect the USB cable to the computer. Windows should automatically detect the cable and state that the device is now ready to use.

Post-Installation Check

Execute the following check after installation:

Step	Action
1	On the target machine, make sure the USB cable is physically connected to the USB port.
2	On the PC, make sure the USB cable is physically connected to the USB port.

Step	Action
3	On the desktop, right-click My Computer and click Properties .
4	In the System Properties dialog box, select the Hardware tab, and then click Device Manager .
5	Confirm that Schneider Electric XBT ZG925 COM3 is listed below Ports [COM & LPT] .

Changing the COM Port Number

The COM port number 3 is assigned automatically by the operating system (OS). If the OS had previously allocated COM 3 or other numbers for devices such as internal modems, IrDA ports, and so on, XBT ZG9255 is allocated to the next available COM number. However if required, you can change the COM port number.

Step	Action
1	In the Control Panel, click on System Properties and select Device Manager .
2	Click to expand the Ports [COM & LPT] folder, right-click the Schneider Electric XBT ZG925 COM 3 node, and then click Properties .
3	In the Schneider Electric XBT ZG925 [COM 3] Properties dialog box, click the Port Settings tab, and click the Advanced button.
4	At the bottom of the Advanced Settings for COM 3 dialog box, select an unused number and click OK .
5	When the following Communication Port Properties dialog box appears, click Yes .

Troubleshooting

Problem/Symptom	Solution
The USB cable is not recognized.	Connect the cable correctly, or restart your PC. Also, when connecting a USB hub, make sure to connect it directly to your PC's USB port.
The Plug and Play is not functioning correctly.	
You are unable to use the USB cable after connecting it to a USB hub.	The power supplied from the hub may be insufficient. Make sure the hub is self-powered.
	Connect the cable directly to the PC USB port.
After installation, a ? is displayed when you try to confirm the cable's status via the Device Manager.	The driver has not been installed correctly. Uninstall the driver and re-install it.

Uninstalling the USB Driver

Unplug the USB data transfer cable from the PC and double-click on the CD-ROM's DRemover2K.exe file to start the uninstallation process.

4.4 Ethernet Cable Connector

Presentation

Introduction

The XBT GT series (except for the XBT GT1100/1105/2110/2120/2220 models) and the XBT GK series (except for the XBT GK2120) comes equipped with an IEEE 802.3 compliant Ethernet interface, that transmits and receives data at 10 Mbps or 100 Mbps.

Ethernet Cable Connector

The following illustration displays the location of the RJ45 Ethernet cable connector:

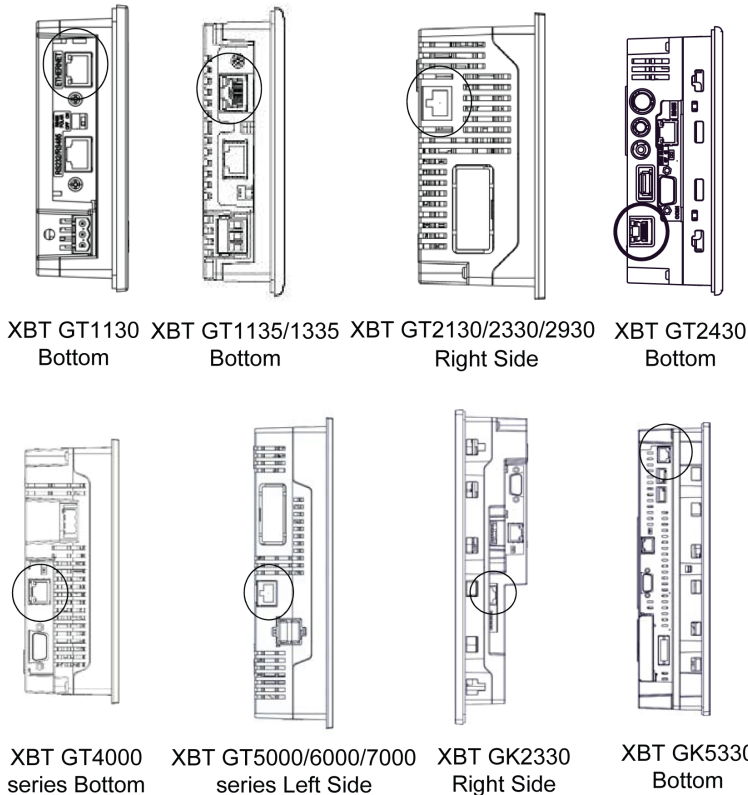

CAUTION

IMPROPER CONNECTIONS CAN DAMAGE COMMUNICATION PORTS

- Do not confuse the R-J45 Ethernet connector with the RJ-45 COM1/COM2 serial port.
- Do not connect the serial cable to the Ethernet port.
- Do not connect the Ethernet cable to the serial port.
- Carefully observe the product markings distinguishing between the Ethernet and serial ports.

Failure to follow these instructions can result in injury or equipment damage.

NOTE: Ethernet networks should be installed by a trained and qualified person.

1:1 connections should be made with a hub or a switch. It is possible to use the 1:1 connection with a cross cable depending on the connected PCs and network cards.

4.5

CF Card

CF Card Installation and Removal

Introduction

CF Cards can be used store the following types of data:

- Historical Data
- Recipe Data
- Alarm Data
- Project Backups

Please refer to the Vijeo Designer Online Help for more information on using the CF Card in your project. The following target machines support the use of CF cards:

- XBT GT2000 series (except for XBT GT2110)
- XBT GT4000 series
- XBT GT5000 series
- XBT GT6000 series
- XBT GT7000 series
- XBT GK series
- XBT GH series

Precautions

When using the unit and a CF card, follow the precautions below:

- Prior to inserting or removing a CF card, be sure that the ACCESS lamp is not flashing. Only remove the CF card when the light is either OFF or Solid Green. If you do not, CF card internal data may be damaged or lost. See Location of CF Card DIP Switches for details.
- Check that the CF card DIP switch settings are appropriate (*see page 105*).
- While a CF card is being accessed, never turn OFF or reset the unit, or insert or remove the CF card. Prior to performing these operations, use Vijeo Designer to create and use a special unit application screen that will prevent access to the CF card. See Vijeo Designer online help for further details.
- Prior to inserting a CF card, familiarize yourself with the CF card's front and rear face orientation, as well as the CF card connector's position. If the CF card is not correctly positioned when it is inserted into the unit, the CF card's internal data and the unit may be damaged or broken.
- Be sure to use only CF cards manufactured by Schneider Electric.
- Once unit data is lost, it cannot be recovered. Since accidental data loss can occur at any time, be sure to back up all unit screen and CF card data regularly. See the Vijeo Designer Online Help for more information on backing up your unit's data.

CAUTION

CF CARD DATA LOSS

- Do not bend the CF card.
- Do not drop or strike the CF card against another object.
- Keep the CF card dry.
- Do not touch the CF card connectors.
- Do not disassemble or modify the CF card.

Failure to follow these instructions can result in injury or equipment damage.

Inserting the CF Card

Use the following steps to insert the CF card.

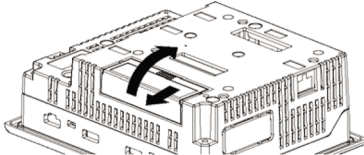
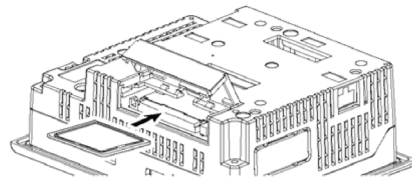
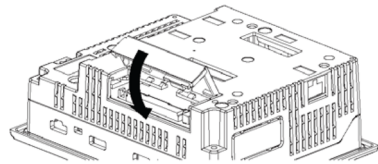
Step	Action
1	Slide the CF card cover in the direction shown here, then upwards to open the cover. 
2	Insert the CF card in the CF card Slot, until the ejector button is pushed forward. 
3	Close the cover. (As shown). 
4	Confirm that the CF Card Access LED turns ON. You cannot access the CF Card with the CF Card cover opened. However, if the CF Card is being accessed, the access will continue even if you open it on the way.

Removing the CF Card

Simply reverse the steps shown in the previous procedure.

Prior to removing the CF card, confirm that the **CF Card Access** LED is turned OFF.

The following figure displays how to remove the CF card:

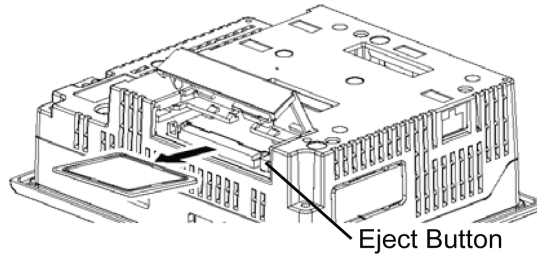

CF Card Handling

The CF card has a life expectancy of 100,000 write cycles. Therefore, be sure to back up all CF card data regularly to another storage media. (100,000 times assumes the overwriting of 500 kilobytes of data in DOS format). See Vijeo Designer online help for information on managing CF Card data.

The following table presents two methods to back up data.

If	Then	And
Your PC is equipped with a PC card slot	To view CF card data on a personal computer, first, insert the CF card into a CF card adaptor XBT ZGADT.	Save data CF card on the PC.
Your PC is not equipped with a PC card slot	Use a standard XBT ZGADT type PC Card or CF card reader.	Save data CF card on the PC.

NOTE: Depending on the setup of your PC, it is possible that the card reader may not operate correctly.

The connection between a personal computer and CF card reader has been tested using a Windows® compatible machine. Check that CF card reader is correctly installed and configured. Please contact your PC or CF card reader manufacturer directly for details.

4.6

USB Port

Overview

This section presents the USB port.

What Is in This Section?

This section contains the following topics:

Topic	Page
Important Considerations When Using the USB Port	183
USB Data Transfer Cable (XBT ZG935) - USB Driver Installation	184
USB Clamp	186
USB Holder	190

Important Considerations When Using the USB Port

Introduction

The following units have a USB port:

- XBT GT1005 series
- XBT GT2000 series
- XBT GT4000 series
- XBT GT5000 series
- XBT GT6000 series
- XBT GT7000 series
- XBT GK series
- XBT GH series

Data transfer cable (XBT ZG935) can be attached to the USB port to allow transferring of data from the computer to the unit.

DANGER

RISK OF EXPLOSION

Confirm that the USB cable has been attached with the USB cable clamp (for XBT GT2000 and XBT GK series) or the USB holder (for XBT GT1005, 4000, 5000, 6000 and 7000 series) before using the USB host interface in hazardous locations as described in UL1604.

Failure to follow these instructions will result in death or serious injury.

USB Data Transfer Cable (XBT ZG935) - USB Driver Installation

Important information

Follow the procedure described below to prevent damage to the cable connector or the unit.

- Do not connect the USB data transfer cable until told to do so in the instructions.
- When connecting the USB data transfer cable to the PC or to the unit, insert the cable's connector at the correct 90° angle.
- When disconnecting the cable, make sure to hold the connector, not the cable itself.
- If the cable is unplugged from the port designated during installation and connected to a different port, the OS will not recognize the new port. Therefore, make sure to always use the port designated during installation.
- If the installation does not complete successfully, restart the PC and quit all resident applications before re-installing the software.

NOTE: Vijeo Designer must be installed before installing the USB driver.

Installation Procedure for Windows 2000, XP, and Vista

Step	Action
1	Insert the Vijeo Designer Installation CD-ROM into your CD-ROM drive. The Setup window for Vijeo Designer should open automatically. If not, at the Windows Start menu, click Run and type x:\install.exe (where x is your CR-ROM drive name).
2	In the install menu, select USB Driver .
3	Select the driver you want to install from the window that appears. For the XBT ZG935 USB cable, select Install USB driver for XBTGT2000 Series and higher .
4	A popup window appears stating the installation of the driver was successful.
5	Connect the USB cable to the computer. Windows should automatically detect the cable and state that the device is now ready to use.

Post-Installation Check

Perform the following check after installation:

Step	Action
1	On the target machine, make sure the USB cable is physically connected to the USB port.
2	On the PC, make sure the USB cable is physically connected to the USB port.
3	On the desktop, right-click My Computer and click Properties .
4	In the System Properties dialog box, select the Hardware tab, and then click Device Manager .
5	In the Device Manager, the USB link cable (XBT ZG935) should display below the USB controller.

Troubleshooting

Problem/Symptom	Solution
The USB cable is not recognized.	Connect the cable correctly, or restart your PC. Also, when connecting a USB hub, make sure to connect it directly to your PC's USB port.
Overcurrent occurred	
The Plug and Play is not functioning correctly.	
You are unable to use the USB cable after connecting it to a USB hub.	The power supplied from the hub may be insufficient. Make sure the hub is self-powered.
	Connect the cable directly to the PC USB port.
After installation, a ? is displayed when you try to confirm the cable's status via the Device Manager.	The driver has not been installed correctly. Uninstall the driver and re-install it.

Uninstalling the USB Driver

Step	Action
1	Click the USB device icon Stop USB link cable in the Windows task tray and then click Stop USB link cable (XBT ZG935) for Windows 2000, or Safely remove USB link cable (XBT ZG935) for Windows XP.
2	When the Safe To Remove Hardware message box appears, remove the USB download cable.
3	Click OK to close the message box.

USB Clamp

Introduction

When using a USB device, you can attach a USB clamp to the USB interface on the side of the unit to prevent the USB cable from being disconnected. The USB clamp can be used with the following units:

- XBT GT2000 series
- XBT GK series

CAUTION

LIVE VOLTAGE

Remove power before attaching or detaching any connector(s) to or from the unit.

Failure to follow these instructions can result in injury or equipment damage.

Attaching the USB Clamp to the XBT GT Series

Step	Action
1	Insert the USB clamp into the slot in front of the unit's USB port and pull it down and forward.

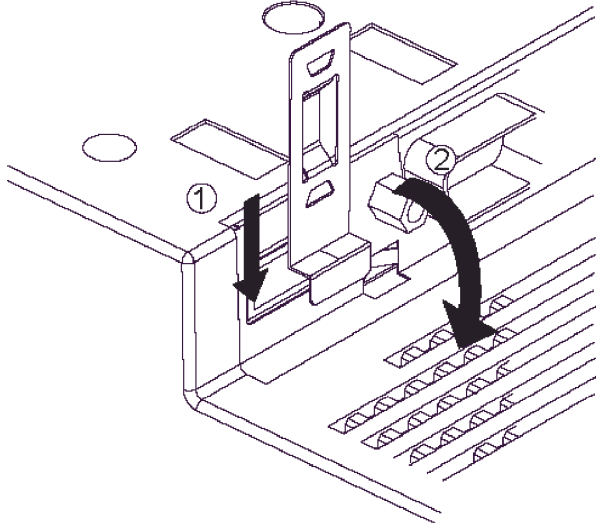

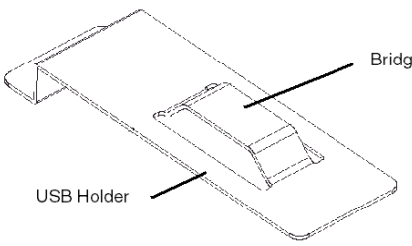
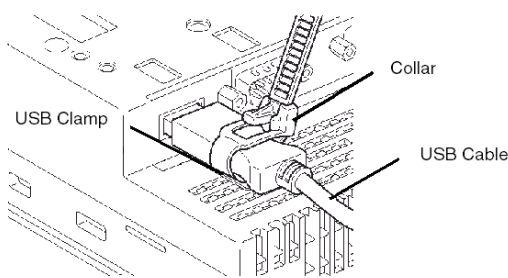
Step	Action
2	Pass the band of the USB collar through the bridge of the USB clamp. 
3	Insert the USB cable into the port. Fasten the band around the plug and secure it with the collar. 

Attaching the USB Clamp to the XBT GK Series

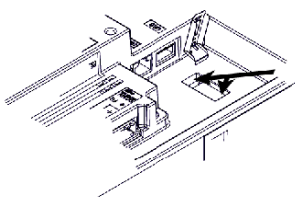
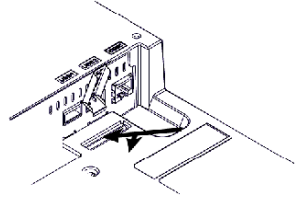
Step	Action
1	Attach the USB clamp to the USB Host Interface on the main unit. Insert the USB clamp into the USB clamp places as shown in the picture below. <div style="display: flex; justify-content: space-around; margin-top: 10px;"> <div style="text-align: center;"> <p data-bbox="500 1133 734 1153">XBT GK 2120/2330 series</p>  </div> <div style="text-align: center;"> <p data-bbox="916 1133 1104 1153">XBT GK 5330 series</p>  </div> </div>

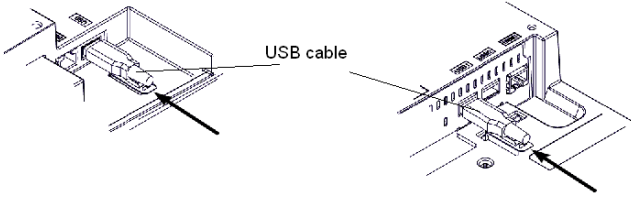
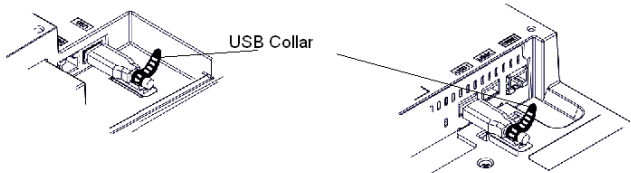
Step	Action
2	<p data-bbox="495 199 961 224">Insert the USB cable into the USB host interface.</p> <div style="display: flex; justify-content: space-around;"> <div data-bbox="515 261 749 285">XBT GK 2120/2330 series</div> <div data-bbox="948 261 1136 285">XBT GK 5330 series</div> </div> 
3	<p data-bbox="495 557 1218 605">Attach the USB collar to the USB cable and to the USB clamp to fix the USB cable in place.</p> <div style="display: flex; justify-content: space-around;"> <div data-bbox="522 643 755 667">XBT GK 2120/2330 series</div> <div data-bbox="934 643 1122 667">XBT GK 5330 series</div> </div>  <p data-bbox="495 870 1087 894">If you are installing a second USB cable, repeat steps 2 and 3.</p>

Releasing the USB Clamp on the XBT GT Series

Lower the tab and lift the collar to release the plug.

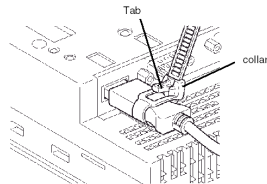

Removing the USB Clamp on the XBT GK Series

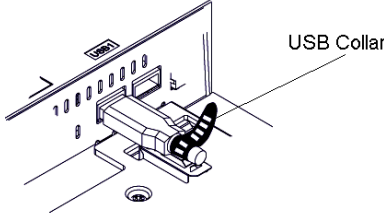
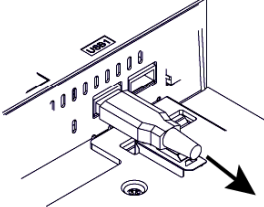
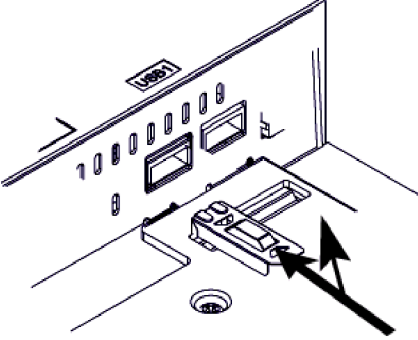
Step	Action
1	<p>Release the USB collar and remove it.</p> <p>XBT GK series</p> 
2	<p>Remove the USB cable.</p> <p>XBT GK series</p> 
3	<p>To remove the USB clamp, lift it up.</p> 

USB Holder

Introduction

When using a USB device, you can attach a USB holder to the USB interface on the side of the unit to prevent the USB cable from being disconnected. The USB holder can be used with the following units:

- XBT GT1005 series
- XBT GT4000 series
- XBT GT5000 series
- XBT GT6000 series
- XBT GT7000 series

⚠ CAUTION

LIVE VOLTAGE

To prevent an electric shock, unplug the unit's power cord from the 24 Vdc power supply prior to attaching or detaching any connector(s) to or from the unit.

Failure to follow these instructions can result in injury or equipment damage.

Attaching the USB Holder

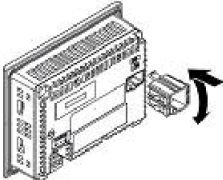
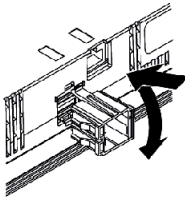
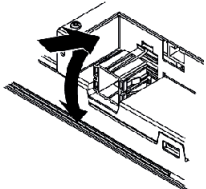
Step	Action
1	<p>Attach the USB holder to the USB Host Interface on the main unit. Hook the upper pick of the USB holder to the attachment hole of the main unit, and insert the lower pick as shown below to fix the USB holder.</p> <p>XBT GT1005 series</p>  <p>XBT GT4000/5000/6000 series</p>  <p>XBT GT7000 series</p> 

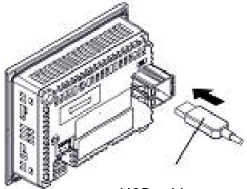
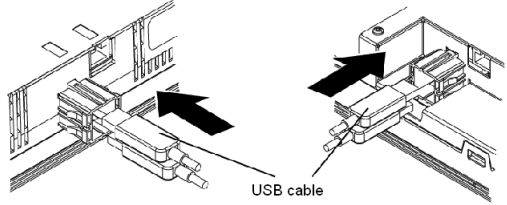
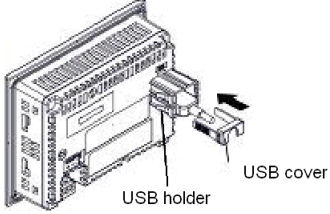
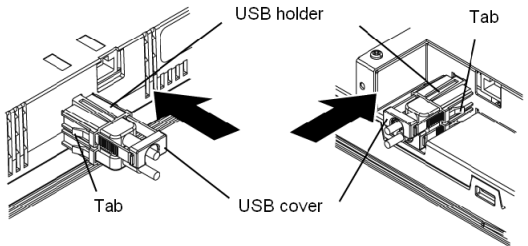
Step	Action
2	<p data-bbox="473 203 939 227">Insert the USB cable into the USB host interface.</p> <p data-bbox="555 243 720 267">XBT GT1005 series</p>  <p data-bbox="651 479 734 495">USB cable</p> <p data-bbox="480 511 727 535">XBT GT4000/5000/6000 series</p> <p data-bbox="843 511 1008 535">XBT GT7000 series</p>  <p data-bbox="775 722 857 738">USB cable</p>
3	<p data-bbox="473 787 1200 836">Attach the USB cover to fix the USB cable in place. Insert the USB cover into the tab of the USB holder.</p> <p data-bbox="555 868 720 893">XBT GT1005 series</p>  <p data-bbox="651 1104 747 1120">USB holder</p> <p data-bbox="775 1079 871 1096">USB cover</p> <p data-bbox="500 1144 747 1169">XBT GT4000/5000/6000 series</p> <p data-bbox="857 1144 1022 1169">XBT GT7000 series</p>  <p data-bbox="747 1177 843 1193">USB holder</p> <p data-bbox="980 1177 1022 1193">Tab</p> <p data-bbox="610 1372 651 1388">Tab</p> <p data-bbox="747 1372 843 1388">USB cover</p> <p data-bbox="473 1437 1063 1461">If you are installing a second USB cable, repeat steps 2 and 3.</p>

Removing the USB Holder

Lift up the tab of the USB holder and then remove the USB cover.

XBT GT1005 series

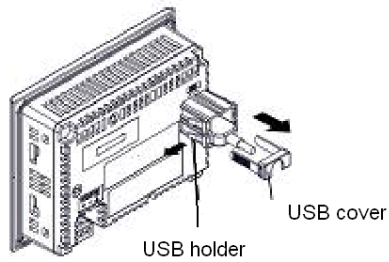

XBT GT4000/5000/6000 series

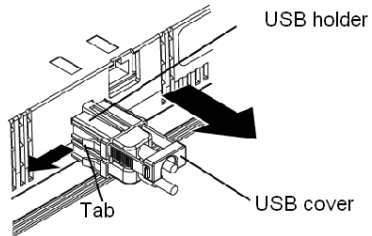

XBT GT7000 series

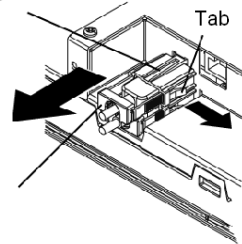

4.7 AUX Connector

AUX Connector

Introduction

You can connect the cable to the AUX connector to perform an external reset input or a speaker output. The AUX connector can be used with the following XBT GT units:

- XBT GT4000 series
- XBT GT5000 series
- XBT GT6000 series
- XBT GT7000 series
- XBT GK5330

⚠ CAUTION

LIVE VOLTAGE

Remove power before attaching or detaching any connector(s) to or from the unit.

Failure to follow these instructions can result in injury or equipment damage.

Installing the AUX Connector

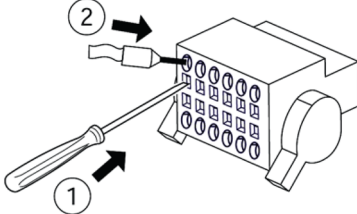
Step	Action
1	Remove 7 mm (.28 in.) of the vinyl cover of each of the wires.
2	If using stranded wire, twist the ends. Tinning the ends with solder reduces risk of fraying and ensures good electrical transfer.
3	Insert a driver into the square-shaped hole.
4	Insert the cable into the circular-shaped hole and pull out the driver. The cable is then fixed.
	
5	Insert the AUX connector into the AUX input/output and sound output interface.

4.8 Cable Connector

Attaching the Cable Connector to the XBT GH

Introduction

The functionality of XBT GH units, such as the use of additional ports and card readers, can be extended by connecting XBT GH units to peripheral devices via a device cable.

NOTICE

INCORRECT USB CONNECTION SEQUENCE

Always connect the connection device side first, and the XBT GH unit side last. Doing otherwise may damage the circuitry of the device or the XBT GH unit.

Failure to follow these instructions can result in equipment damage.

Attaching the Cable Connector

Use the following steps to attach the cable connector to the XBT GH connector.

Step	Action
1	Before connection, remove the cable connector's cap and the XBT GH connector cover. To remove the cable's connector cap, pull out the cable by holding the cable connector. Be sure to hold the cable connector and pull it out. If you hold otehr parts of the cable (lock ring, etc.), the cable cannot be disconnected.
2	Turn the cable connector so that the surface marked with a triangle faces up. Insert the cable connector into the XBT GH connector until it clicks.

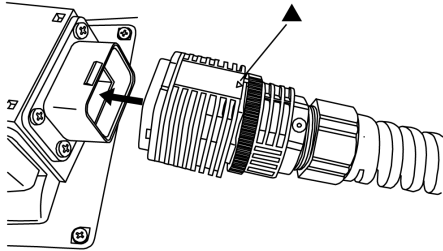

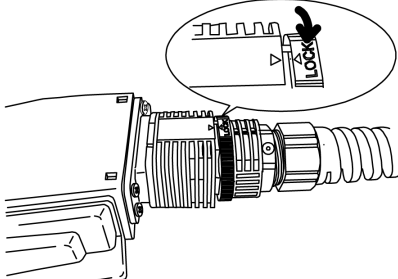
Step	Action
3	<p>Turn the cable connector lock ring (as shown) to lock the connector, so that the triangle mark (for LOCK) on the lock ring is aligned with the triangle mark on the cable connector.</p> 

Removing the Cable Connector

Use the following steps to detach the cable connector from the XBT GH connector.

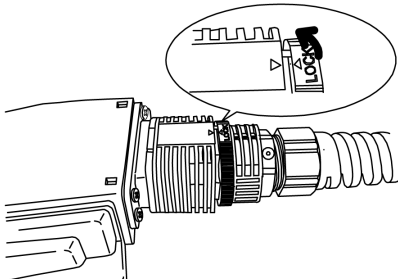
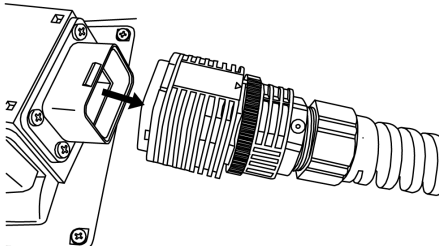
Step	Action
1	<p>Turn the lock ring (as shown) so that the triangle mark on the lock ring is displaced from the triangle mark on the cable connector.</p> 
2	<p>Pull out the cable by holding the cable connector.</p> 

4.9 Emergency Switch Guard

Attaching the Emergency Switch Guard to the XBT GH

Introduction

Install the emergency switch guard to a XBT GH unit to prevent the emergency switch from being accidentally turned on, for example, if the unit is dropped or placed upside down on a desk. The emergency switch guard complies with Safety Category 1 (ISO 13840-1).

WARNING

UNGUARDED EMERGENCY STOP SWITCH

If compliance to the applicable safety standards is necessary in your application, do not use the emergency switch guard (included in the XBT GH unit). If such compliance is not applicable for your application, install the guard to help prevent unintended activation or damage to the switch.

Failure to follow these instructions can result in death, serious injury, or equipment damage.

Attaching the Emergency Switch Guard

Use the following steps to attach the Emergency Switch Guard to the XBT GH.

Step	Action
1	Prepare three screws for mounting the emergency switch guard (included in the XBT GH unit's package with the emergency switch built in).
2	Remove the emergency switch guard hole covers at two places beside the emergency switch (labelled "1" in the image below).

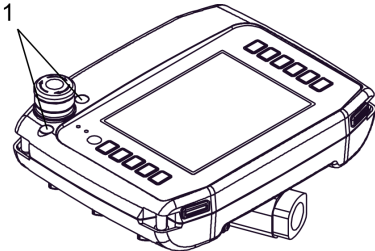

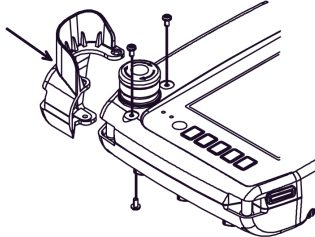
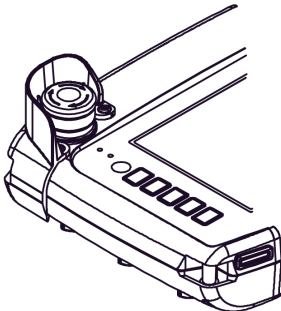
Step	Action
3	<p data-bbox="473 203 1214 276">Align the three screw holes of the emergency switch guard with the screw holes of the XBT GH unit. Fasten the two points in the front, and the one point in the XBT GH unit's rear side with the screws.</p>  <p data-bbox="473 544 1214 592">NOTE: Tightening each screw with excessive torque may result in damage to the equipment. Appropriate tightening torque is 0.5 Nm (4.4 lb-in).</p>
4	<p data-bbox="473 609 1131 633">The following is an illustration of the complete mounting configuration.</p> 

Setting and Debugging

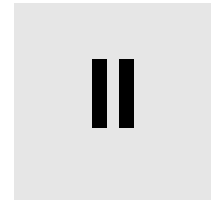

Overview

This part describes the settings available on the target machine as well as how to debug the unit.

What Is in This Part?

This part contains the following chapters:

Chapter	Chapter Name	Page
5	Settings	201
6	Troubleshooting	207
7	Maintenance	215

Settings



5.1 Settings

Overview

This section describes the settings on all XBT GT, XBT GK, and XBT GH units.

What Is in This Section?

This section contains the following topics:

Topic	Page
Types of Settings	202
Offline Settings	203
System Settings	205

Types of Settings

Introduction

You can use the **Settings** menu to configure the unit.

Depending on how you use your XBT GT, XBT GK, or XBT GH, you can display the **Settings** menu using three different methods:

- Use a switch,
- Touch the top-left corner of the panel when powering up,
- Touch two corners of the panel successively while the application is running.

You can select which methods your application uses in the Vijeo Designer editor's Target properties.

Calling Up the Settings Menu

Step	Action
1	<p>Set up any combination of the following methods for displaying the Settings menu.</p> <ul style="list-style-type: none">● Switch: Create a switch and add the Configuration System Operation. See the Vijeo Designer online help for more information on creating a switch.● Top-Left Corner: In the Target properties, set To Configuration to either Top Left Corner or Top Left/2 Corner.● Touch two corners successively: In the Target properties, set To Configuration to either 2 Corner or Top Left/2 Corner. <p>If you set To Configuration to None and do not create a switch to display the Settings menu, then there is no way to configure the unit at runtime.</p>
2	<p>Connect the unit's power supply.</p>
3	<p>Depending on what you set up in Step 1, you can display the Settings menu using one of the following methods:</p> <ul style="list-style-type: none">● Switch: Touch the switch set up with the Configuration system operation.● Top-Left Corner: Touch the top-left corner of the screen within ten seconds after the unit begins starting up.● Touch two corners successively: Touch successively the top left corner then the bottom right corner within half a second. The touch area is 50 dots by 50 dots. <p>Vijeo Designer Runtime restarts and displays the Settings menu.</p>
4	<p>The Settings menu contains two tabs: Offline and System. Click either tab to display its settings.</p>

Offline Settings

Introduction

The offline settings cannot be changed while a user application is running.

Offline Tab

See the Vijeo Designer online help for information on accessing the offline settings tab.

Changing Network Settings

The following procedure applies to all units except the XBT GT1100 and XBT GT1105.

Step	Action
1	In the Settings menu, touch the Offline tab.
2	Touch the Network icon.
3	Touch any of the three fields (IP Address , Subnet Mask , or Default Gateway) and a keypad will appear.
4	Enter the desired network addresses.

NOTE: To apply changes to the network settings restart the unit by touching **To Run Mode** and return to the application.

Changing the Buzzer Settings

Step	Action
1	In the Settings menu, touch the Offline tab.
2	Touch the Buzzer icon.
3	Touch the desired buzzer mode. The factory setting is When Press Touch Object . <ul style="list-style-type: none">● None: Selecting this will turn the buzzer OFF.● When Press Touch Object: The buzzer will only sound when a Touch Object is touched.

Changing Backlight Control

Step	Action
1	In the Settings menu, touch the Offline tab.
2	Touch the Backlight icon.
3	In the Backlight Control , define the backlight operations. <ul style="list-style-type: none">● Wait: To extend the life of the backlight, you can set up the unit so that it turns off the backlight when the panel is inactive (idle) for the defined period of time, (Idle means the unit panel has not been touched). The factory setting for this item is OFF.● Enable Touch if Backlight is Burned Out: this setting defines whether the touch panel is enabled or disabled when a backlight burnout is detected. When this feature is cleared and the backlight burns out, touch inputs are ignored to prevent operation errors. the factory setting for this item is OFF.
4	To turn the backlight off automatically after a specified period of time, touch the Wait checkbox and then set the idle time.

Option

Configure the COM1 port as a power supply.

System Settings

Introduction

You can change system settings while the user application is still running.

System tab

See the Vijeo Designer online help for information on accessing the **System Settings** tab.

Stylus

The stylus setting is not supported for XBT GT1100/1130 and XBT GH series units.

Changing the Date/Time

Step	Action
1	In the Settings menu, touch the System tab.
2	Touch the Date/Time icon.
3	Touch any of the Date or Time fields and a data entry keypad will display. Use this keypad to define the selected date or time setting.

Forcing a Restart

Step	Action
1	In the Settings menu, touch the System tab.
2	Touch the Restart icon.
3	Touch the Restart button to restart the unit.

Selecting a Language

The following table describes how to select the language used for the Settings menu, the run-time messages and user application.

Step	Action
1	In the Settings menu, touch the System tab.
2	Touch the Language icon.
3	Touch the spin boxes to select the desired system and user application languages. The languages available in the language settings are defined in the Vijeo Designer editor.

Displaying Version Information

Step	Action
1	In the Settings menu, touch the System tab.
2	Touch the Ver.Info icon. Version information displays the version number of the runtime and the version and build number of the editor that was used to design the user application.

Displaying Memory Statistics

Step	Action
1	In the Settings menu, touch the System tab.
2	Touch the Memory icon. <ul style="list-style-type: none">• DRAM describes the amount of memory currently being used by the application.• Main Flash indicates the amount of internal memory (flash memory) required to store the runtime system files and the user application.

Brightness/Contrast Control

Step	Action
1	In the Settings menu, touch the System tab.
2	Touch the Brightness icon.
3	Touch the up/down arrows to adjust the brightness and contrast. Reducing the brightness and contrast could increase the life span of the backlight.

Option

In some projects and in some environments, inverting could make the application more visible and reduce eye-strain for the operator working with the target machine.

Step	Action
1	In the Settings menu, touch the System tab.
2	Touch the Option icon.
3	Select Invert to reverse the black and white colors on the screen.

Troubleshooting

6

Overview

This chapter describes how to find and resolve problems with the XBT GT, XBT GK and the XBT GH.

What Is in This Chapter?

This chapter contains the following topics:

Topic	Page
Troubleshooting Checklists	208
Self Test List	212

Troubleshooting Checklists

Introduction

When a problem occurs, to go through the checklist and follow the instructions given.

Here are the main problems that may occur when using an XBT GT, XBT GK or XBT GH.

- Panel display is blank,
- Connected equipment cannot be used,
- Panel does not respond or responds very slowly,
- Panel beeps when powered on,
- Cannot change the date or time.

NOTE: Contact your local Schneider Electric vendor or the vendor who sold you the unit.

Panel Display is Blank

If the unit display is blank, perform the following check steps:.

Step	Check/Operation	Solution
1	Are all Vijeo Designer screens downloaded?	You may have to download the screens again.
2	Is the Initial Panel ID set up correctly in Vijeo Designer?	Enter the Initial Panel ID in the Vijeo Designer editor and download again.
3	Is the unit using the correct rated voltage?	Verify the power supply connections and levels.
4	Is the power supply OFF or disconnected?	Follow the instructions in this manual for reconnecting the power supply.
5	Is the power lamp lit?	A blank power lamp may indicate a problem with the hardware.
6	Is the backlight lit?	The backlight may be burned out or there may be a problem with the unit. Contact your local Schneider Electric distributor, for backlight replacement.
7	Is the problem resolved?	If none of the previous steps fixed the blank panel display problem, then there is a problem with the hardware.

Connected Equipment Cannot be Used

If the unit does not communicate correctly with connected equipment, perform the following check steps:

Step	Check/Operation	Solution
1	Is the power supply OFF or disconnected?	Verify the power supply connections and levels.
2	Do the Driver and Equipment settings in Vijeo Designer match the actual equipment you are trying to communicate with?	In the Vijeo Designer editor's Navigator window's Project tab, expand the I/O Manager node to enter the correct configuration settings for the Driver and Equipment nodes.
3	Is the communication cable connected correctly?	Refer to the associated protocol manual for information about cable diagrams.
4	Is the problem resolved?	If none of the previous steps fixed the communication problem, then there is a problem with the hardware.

Unit does not respond when touched

If the unit is either not responding when touched or if its response time is very slow, perform the following check steps:

Step	Check/Operation	Solution
1	Disconnect all the cables except the power cable.	-
2	In the Settings menu, touch the Offline tab and then touch the Self Test icon. Run the Touch Panel test.	If the test fails, there is a problem with the hardware.
3	Enter the Settings menu, touch the System tab and then touch the Stylus icon. Calibrate the analog touch.	If the touch calibration is not possible, there is a problem with the hardware.
4	If touch response is slow, does it happen on a specific panel?	If the panel displays the values of a large number of equipment variables, you may want to redesign the panel and separate the variables into different panels and download again.

Step	Check/Operation	Solution
5	If touch response is slow, the target's CPU may be very busy communicating with external equipment.	<p>To resolve this problem, try each of the following in the Vijeo Designer editor and download again.</p> <ul style="list-style-type: none"> ● If you are using serial communication, make sure the communication speed between the target and equipment is optimized. ● In the equipment or scan group properties, reduce the Scan Rate to Slow. This will reduce the frequency of variable updates to 1000 ms. ● If you use many equipment variables in application scripts, you may want to change the script to a panel script so that the variables are active only when the information is necessary. <p>If none of the above works, then you may have to reduce the number of external variables in the project.</p> <p>If none of the proposed options work, contact your Schneider Electric Technical Support for other methods of optimizing your project.</p>

Target beeps when powered ON

If the target beeps continually when you turn ON the power supply, then the system files on the unit have become corrupted.

To resolve this problem, go to the Vijeo Designer Start menu and run Recovery on the target machine.

Cannot change the Date or Time

If you cannot change the date or time:.

Problem	Solution
The date and time keeps reverting to a different date and time when you try to change the date or time. The lithium backup battery for the internal clock has probably run out of power.	<ul style="list-style-type: none"> ● Run the unit continuously for 24 hours, (the battery needs 96 hours to be fully charged). ● Try to change the clock setting again.
If the symptom continues, the battery may need replacement.	Contact your local Schneider Electric distributor for service.

 WARNING

BATTERY EXPLOSION

Do not attempt to replace the battery.

Failure to follow these instructions can result in death, serious injury, or equipment damage.

NOTE: The lifetime of the backup battery depends on the ambient temperature.

The expected battery life is more than 10 years when the unit ambient temperature is less than 25° C (77° F).

Self Test List

Introduction

The XBT GT, XBT GK, and XBT GH units are equipped with a number of diagnostic features that can be used to check the systems and the interfaces for any problems.

Self Test

From the **Settings** menu, touch the **Offline** tab and then the **Self Test** icon. **Self Test** menu appears. See the Vijeo Designer online help for information on accessing the **Offline** tab.

Self Tests

The following tests can be accessed from the **Self Test** menu.

Test	Description
Char. Pattern	Checks the characters in each font set available on the unit. Use this test when characters (usually 2-byte characters) do not display properly. OK appears if operation is normal; NG appears if an error is detected.
Disp. Pattern	Use this test when your drawings do not display properly.
Touch Panel	Tests the touch panel cells. Each cell highlights when it's pressed during the test.
COM 1	Checks to make sure the serial port (RS-232C and RS-485) is working properly. To run the check, you may need to connect a loopback cable (see below). OK appears if operation is normal; NG appears if an error is detected.
COM 2	
Video Memory	Use this check to test the video memory (memory used for screen display). Run this test when the screen does not display properly. OK appears if operation is normal; NG appears if an error is detected.

Wiring for COM 1, COM 2 tests

When testing the serial port, depending on which port and which communication format you are testing, you may need to attach a loopback cable with wiring as defined below:

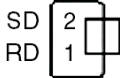
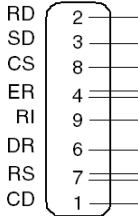
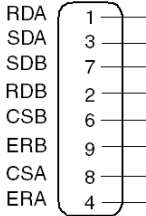
RS-232C	RS-422
<p>XBT GT1000 in COM1</p> 	<p>Not available.</p>
<p>XBT GT2000 in COM1</p> 	<p>XBT GT2000 in COM1</p> 
<p>-</p>	<p>XBT GT2000 in COM2 Not available</p>

Maintenance



Overview

This chapter explains how to maintain your XBT GT, XBT GK, and XBT GH.

What Is in This Chapter?

This chapter contains the following topics:

Topic	Page
Regular Cleaning	216
Periodic Check Points	217
Replacing the Backlight	218

Regular Cleaning

Cleaning the display

When the surface or the frame of the display gets dirty, soak a soft cloth in water with a neutral detergent, wring the cloth tightly, and wipe the display.

Do not use paint thinner, organic solvents, or a strong acid compound to clean the unit.

Cleaning the Gasket

The gasket protects the unit and improves its water resistance.

NOTICE

GASKET AGING

- Inspect the gasket periodically as required by your operating environment to keep the initial IP level.
- Change the gasket at least once a year, or as soon as scratches or dirt become visible.

Failure to follow these instructions can result in equipment damage.

During normal maintenance and reinstallation, check the gasket for dirt and scratches.

Inserting the Gasket

The gasket must be inserted correctly into the groove to comply with IP65.

NOTE: The protection level of the product may vary from that which is shown on the ATEX label, as the value on the ATEX label takes into account product aging.

The upper surface of the gasket should protrude approximately 2 mm (0.08 in.) out from the groove. Verify that the gasket is correctly inserted before installing the unit into a panel.

NOTE: Be sure the gasket's seam is inserted into the straight bottom section of the groove. Inserting it into a corner may lead to eventual tearing.

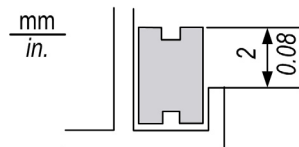

Periodic Check Points

Operation Environment

- The operating temperature should be within the allowable range 0...50 °C (32...122 °F).
- The operating humidity should be within the specified range (10...90 %RH), dry bulb temperature of 39 °C (102 °F) or less.
- The operating atmosphere should be free of corrosive gases.

Electrical Specifications

The input voltage should be within 19.2...28.8 Vdc.

Related Items

- Are all power cords and cables connected properly? Have any become loose?
- Are all mounting brackets holding the unit securely?
- Are there many scratches or traces of dirt on the installation gasket?

Replacing the Backlight

Introduction

The backlights in the following units can be replaced:

- XBT GT5000 series
- XBT GT6330 RL08 or less
- XBT GT6340 RL07 or less
- XBT GT7340 RL08 or less

Please see the Instruction Sheet that comes with replacement backlights for details on how to replace the backlight. Contact your local distributor for more information.

For units not listed above, the unit must be returned to an authorized Schneider Electric repair center for backlight replacement. When the backlight need to be replaced, please contact your local distributor.

WARNING

BACKLIGHT AREA IS HOT

- Let the product cool down for 10 minutes before removing the backlight.
- Wear gloves to touch the inner components.

Failure to follow these instructions can result in death, serious injury, or equipment damage.

WARNING

EXPOSED ELECTRICAL COMPONENTS

- Remove power cords and disconnect all cables, including communication cables, before opening the product.
- Do not open the product for any reason except backlight replacement.

Failure to follow these instructions can result in death, serious injury, or equipment damage.

CAUTION

BROKEN BACKLIGHT

- Do not touch the glass directly.
- Disconnect the PCB connector from the board only.
- Do not try to remove the backlight's PCB connector leads from the backlight.
- Refer to backlight replacement kit quick reference guide for complete details.

Failure to follow these instructions can result in injury or equipment damage.

How to Determine if the Backlight is Burned Out

If your unit's backlight suddenly turns OFF, use the following steps to determine if the backlight is actually burned out:

- If the unit's Backlight Control is not set and the screen has gone blank, your backlight is burned out.
- If the unit's Backlight Control is set to standby mode, the screen has gone blank, and touching the screen or performing another input operation does not cause the display to reappear, your backlight is burned out.

Index

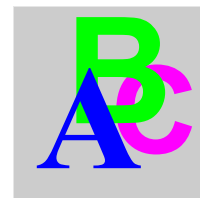

Symbols

Peripherals

Edit Mode, *24*

Run Mode, *26, 27*

A

Accessories, *28*

AUX Connector, *193*

C

Cable Connector

Installation, *194*

Removal, *195*

Certifications and Standards, *20*

CF Card

Installation, *179*

Removal, *181*

Clock, *50*

Connecting the Power Cord, *164*

Connecting the Power Supply, *167*

D

DIP Switches, *104*

E

Edit Mode Peripherals, *24*

Emergency Switch Guard

Installation, *196*

Ethernet

Cable connector, *177*

Interface, *61*

F

Fasteners, *153*

G

Grounding, *169*

I

insert label XBT GH, *57*

insert label XBT GK, *57*

Installation

Cable Connector, *194*

CF Card, *179*

Emergency Switch Guard, *196*

Fasteners, *153*

Procedures, *156*

USB Driver, *174*

L

label

- insert label XBT GH, *57*
- insert label XBT GK, *57*
- inserting insert labels, *57*
- printing insert labels, *57*

M

Maintenance

- Check points, *217*
- Cleaning, *216*
- Replacing the backlight, *218*

Memory, *49*

O

Offline Settings, *203*

P

Panel Cut-out Dimensions, *151*

Part number

- XBT GH2460, *15*
- XBT GK2120, *15*
- XBT GK2330, *15*
- XBT GK5330, *15*
- XBT GT1100, *14*
- XBT GT1105, *14*
- XBT GT1130, *14*
- XBT GT1135, *14*
- XBT GT1335, *14*
- XBT GT2110, *14*
- XBT GT2120, *14*
- XBT GT2130, *14*
- XBT GT2220, *14*
- XBT GT2330, *14*
- XBT GT2430, *14*
- XBT GT2930, *14*
- XBT GT4230, *14*
- XBT GT4330, *14*
- XBT GT4340, *14*
- XBT GT5230, *14*
- XBT GT5330, *14*
- XBT GT5340, *14*
- XBT GT5430, *14*
- XBT GT6330, *14*
- XBT GT6340, *15*
- XBT GT7340, *15*

Parts Identification and Functions, *73*

Power plug, *165*

R

Run Mode Peripherals, *26, 27*

S

Selector Switches, *104*

Self Test, *212*

Settings

- menu, *202*

Specifications

- 3-Position Switch, *56*
- Alphanumeric Keys, *53*
- COM, *64*
- COM1, *60, 64*
- COM2, *61, 68*
- Cursor Keys, *52*
- Display, *43*
- Electrical, *37*
- Emergency Switch, *55*
- Environmental, *38*
- Ethernet, *61*
- Fine Tuning, *54*
- Interfaces, *60*
- Key Switch, *54*
- Keypads, *52*
- LEDs, *54*
- Memory, *62*
- Operation Switch, *55*
- Pointer, *52*
- Pointer, Keypads, Switches and LEDs, *52*
- Structural, *40*
- USB, *62*

STN, *43*

System Settings, *205*

T

TFT, *44*

Tool Port Connector, *173*

Touch panel, *50*

Troubleshooting, *208*

U**USB**

- Cable Clamp, *186*
- Data Transfer Cable, *184*
- Driver Installation, *174*
- Holder, *190*
- Port, *183*

X**XBT GH2460**

- Dimensions, *149*
- Offline Settings, *203*
- Parts Identification, *100*
- System Settings, *205*

XBT GK2120

- Dimensions, *141*
- Offline Settings, *203*
- Panel Cut-out Dimensions, *151*
- Parts Identification, *94*
- System Settings, *205*

XBT GK2330

- Dimensions, *141*
- Offline Settings, *203*
- Panel Cut-out Dimensions, *151*
- Parts Identification, *94*
- System Settings, *205*

XBT GK5330

- Dimensions, *145*
- Offline Settings, *203*
- Panel Cut-out Dimensions, *151*
- Parts Identification, *97*
- System Settings, *205*

XBT GT1100

- Dimensions, *109*
- Offline Settings, *203*
- Panel Cut-out Dimensions, *151*
- Parts Identification, *73*
- System Settings, *205*

XBT GT1105

- Dimensions, *120*
- Offline Settings, *203*
- Panel Cut-out Dimensions, *151*
- Parts Identification, *74*

XBT GT1105

- System Settings, *205*

XBT GT1130

- Dimensions, *109*
- Offline Settings, *203*
- Panel Cut-out Dimensions, *151*
- Parts Identification, *73*
- System Settings, *205*

- XBT GT1135
 - Dimensions, *120*
 - Offline Settings, *203*
 - Panel Cut-out Dimensions, *151*
 - Parts Identification, *74*
 - System Settings, *205*
- XBT GT1335
 - Dimensions, *120*
 - Offline Settings, *203*
 - Panel Cut-out Dimensions, *151*
 - Parts Identification, *74*
 - System Settings, *205*
- XBT GT2110
 - Dimensions, *124*
 - Offline Settings, *203*
 - Panel Cut-out Dimensions, *151*
 - Parts Identification, *76*
 - System Settings, *205*
- XBT GT2120
 - Dimensions, *124*
 - Offline Settings, *203*
 - Panel Cut-out Dimensions, *151*
 - Parts Identification, *76*
 - System Settings, *205*
- XBT GT2130
 - Dimensions, *124*
 - Offline Settings, *203*
 - Panel Cut-out Dimensions, *151*
 - Parts Identification, *76*
 - System Settings, *205*
- XBT GT2220
 - Dimensions, *124*
 - Offline Settings, *203*
 - Panel Cut-out Dimensions, *151*
 - Parts Identification, *76*
 - System Settings, *205*
- XBT GT2330
 - Dimensions, *124*
 - Offline Settings, *203*
 - Panel Cut-out Dimensions, *151*
 - Parts Identification, *76*
 - System Settings, *205*
- XBT GT2430
 - Dimensions, *124*
 - Offline Settings, *203*
 - Panel Cut-out Dimensions, *151*
 - Parts Identification, *78*
 - System Settings, *205*
- XBT GT2930
 - Dimensions, *124*
 - Offline Settings, *203*
 - Panel Cut-out Dimensions, *151*
 - Parts Identification, *76*
 - System Settings, *205*
- XBT GT4230
 - Dimensions, *121*
 - Offline Settings, *203*
 - Panel Cut-out Dimensions, *151*
 - System Settings, *205*
- XBT GT4320
 - Dimensions, *121*
 - Offline Settings, *203*
 - Panel Cut-out Dimensions, *151*
 - Parts Identification, *80*
 - System Settings, *205*
- XBT GT4330
 - Dimensions, *121*
 - Offline Settings, *203*
 - Panel Cut-out Dimensions, *151*
 - Parts Identification, *80*
 - System Settings, *205*
- XBT GT5230
 - Dimensions, *125*
 - Offline Settings, *203*
 - Panel Cut-out Dimensions, *151*
 - Parts Identification, *83*
 - System Settings, *205*
- XBT GT5330
 - Dimensions, *129*
 - Offline Settings, *203*
 - Panel Cut-out Dimensions, *151*
 - Parts Identification, *85*
 - System Settings, *205*

XBT GT5340

- Dimensions, *129*
- Offline Settings, *203*
- Panel Cut-out Dimensions, *151*
- Parts Identification, *85*
- System Settings, *205*

XBT GT5430

- Dimensions, *129*
- Offline Settings, *203*
- Panel Cut-out Dimensions, *151*
- Parts Identification, *85*
- System Settings, *205*

XBT GT6330

- Dimensions, *133*
- Offline Settings, *203*
- Panel Cut-out Dimensions, *151*
- Parts Identification, *88*
- System Settings, *205*

XBT GT6340

- Dimensions, *133*
- Offline Settings, *203*
- Panel Cut-out Dimensions, *151*
- Parts Identification, *88*
- System Settings, *205*

XBT GT7340

- Dimensions, *137*
- Offline Settings, *203*
- Panel Cut-out Dimensions, *151*
- Parts Identification, *91*
- System Settings, *205*

